

All-in-one Air-cooled **ESS ECO-E215WS Cabinet**

User Manual

Installation Manual

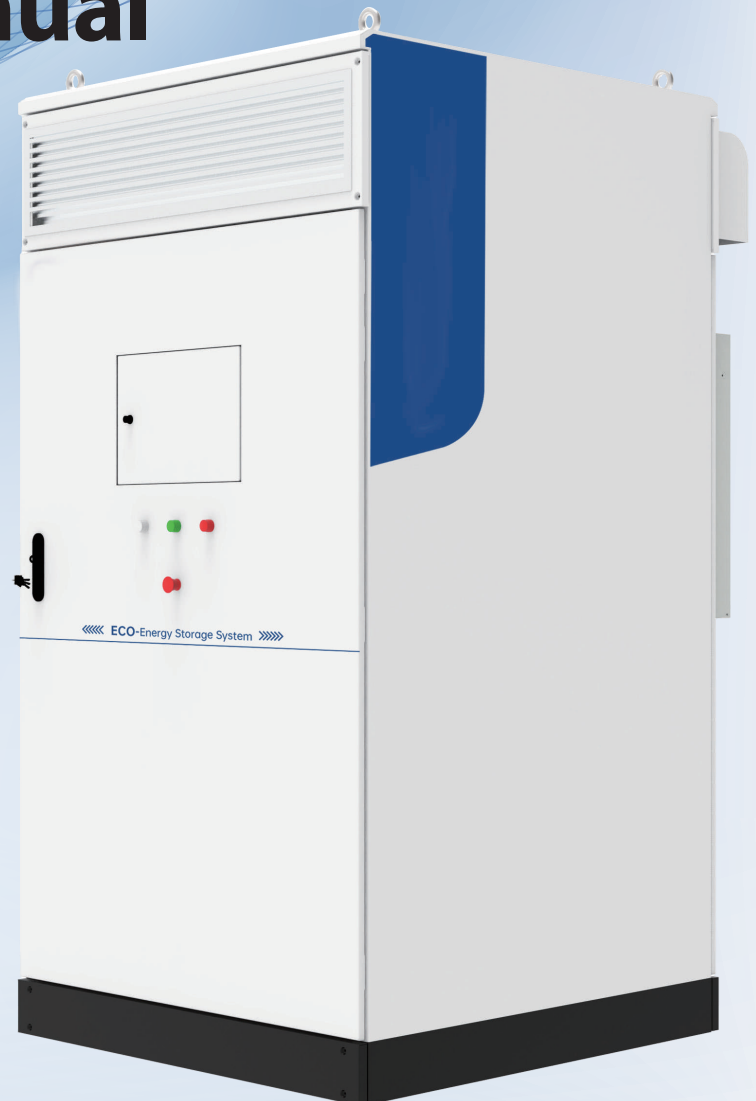

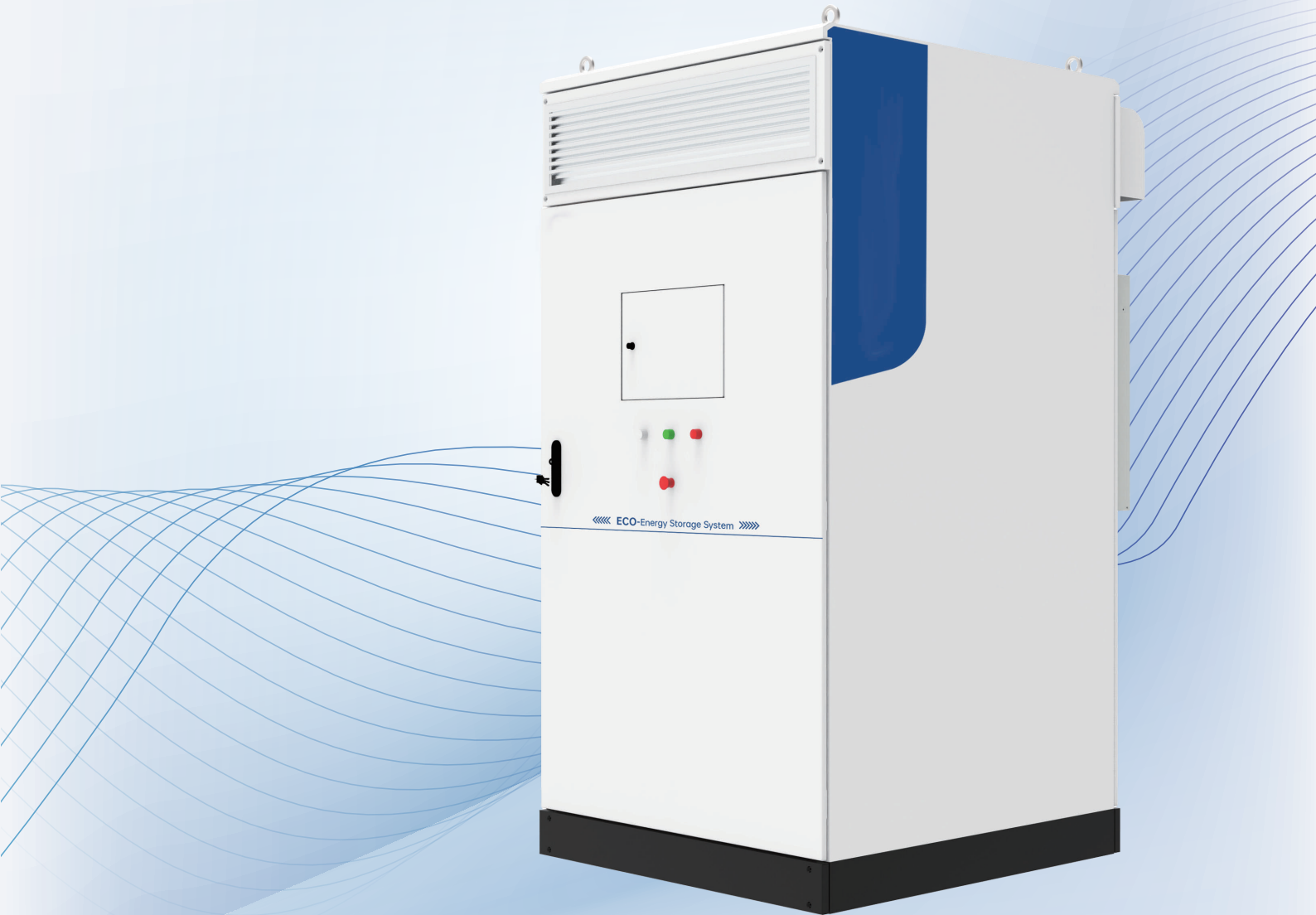

All-in-one Air-cooled

ESS ECO-E215WS Cabinet User Manual

The release date identified in the change history for this Manual is correct. We reserve the right to modify products and documentation at any time.

The images provided in this Manual are for demonstration purposes only. Details vary slightly based on product version and market region. We have the final right of interpretation on all detailed designs of products.

The information and advice stated are given in good faith and believed to be accurate as of the date of editing. We make no warranties, express or implied, regarding this information.

Table of Contents

1. About this manual	01
1.1 Preface	
1.2 Applicable products	
1.3 Technical parameters	
1.4 Security Statement	
1.5 Safety instructions	
2. Product description	03
2.1 System Overview	
2.2 Technical parameters	
2.3 System diagram	
2.4 Communication control	
2.5 Port description	
2.6 PCS	
2.7 Fire suppression system	
3. Equipment operation	19
3.1 Hazards	
3.2 Operation precautions	
3.3 Cabinet panel description	
3.4 Connection and Power-on of ECO-E215WS	
3.5 Charging and Discharging of ECO-E215WS	
3.6 Power-off Operation of ECO-E215WS	
3.7 Operation Instructions for Upper Computer	
3.8 Operation Instructions for HMI	
3.9 Operation Instructions for WEB Platform	
3.10 Operation Instructions for Mobile Application	
4. Maintenance	27
4.1 Interpretation of Terms	
4.2 Use Requirements for Normally-operating System	
4.3 Use Requirements for Intermittently-operating System	
4.4 Use Requirements for Long-term Idle System	
4.5 Operation Methods for Battery Maintenance	
5. Fault Handling of Energy Storage System	28
5.1 Handling Methods for Common Faults	
5.2 Handling Methods for Emergency Faults	
6. Warranty Statement	29
7. After-sales Service	29
Annex 1	

1. About this manual

1.1 Preface

Dear user, much appreciation for using the all-in-one air-cooled ESS cabinet ECO-E215WS product developed and produced by Shanghai Elecnova Energy Storage Technology Co., Ltd. We sincerely hope that this product can meet your needs, and we also hope that you will be satisfied with the product performance and provide valuable comments and suggestions. We will continue to evolve and continuously improve product quality.

1.2 Applicable products

This manual is applicable to product model: all-in-one air-cooled ESS cabinet ECO-E215WS.

1.3 Brief introduction

The manual contains the following main contents:

- safety instructions

Introduces the precautions for safe operation of ECO-E215WS.

- product description

An overview of ECO-E215WS and related technical parameters are introduced.

- product operations



Introduces the operation of ECO-E215WS switch-on and -off and HMI operation.

- other

Introduces the troubleshooting methods of ECO-E215WS and our company's contact information.

1.4 Security Statement

In this manual, the following instructions indicate "DANGER"; "WARNING" and "ATTENTION" tags are used to deliver information related to specific tasks, procedures and procedure-related hazards. These safety precautions do not represent all hazards present when performing a given task. ECO-E215WS installers and operators should adhere to premium industrial safety practices; site-specific ambience, health and safety plans; and local safety requirements and regulations. **Only properly trained and qualified personnel are allowed to complete the installation procedures identified in this manual.**

	<p>"DANGER" indicates a hazardous situation which, if not avoided, will result in death or serious injury. "DANGER" is only limited to the most extreme cases. The "DANGER" indicator is not used for property damage hazards unless there is also a risk of personal injury corresponding to these levels.</p>
	<p>"WARNING" indicates a hazardous situation which, if not avoided, could result in death or serious injury. The "WARNING" indicator is not used for property damage hazards unless there is also a risk of personal injury appropriate to those levels.</p>
	<p>"CAUTION" indicates a hazardous situation which, if not avoided, may result in minor or moderate injury. The "CAUTION" indicator can be used to warn of unsafe operations that could result in property damage.</p>

1.5 Safety instructions

1.5.1 Safety notice

This chapter introduces the general safety principles that need to be paid attention to when operating ECO-E215WS. Please read this safety instructions before operating. For specific safety matters, please refer to the corresponding chapter instructions .

	<p>Touching the terminals, contacts, etc. connected to the power grid or ESS cabinet may result in death from electric shock!</p> <p>Lethal high voltage inside, pay attention to and follow the warning labels on the product!</p> <p>Damaged internal component may cause electric shock or fire!</p>
---	--

1.5.2 Manual storage

Please read this manual carefully before using this product and keep it in a safe place .

Please strictly follow the description in this manual to operate ECO-E215WS. Otherwise, product damage, property damage, and property damage may occur.

The losses may even lead to serious accidents such as casualties.

Please strictly follow the description in this manual to operate ECO-E215WS. Otherwise, serious accidents such as product damage, property loss, or even personal injury or death may occur.

1.5.3 Personnel requirements



	<p>Staff who perform electrical work on this product must undergo professional training and hold relevant work operation certificates!</p>
---	--

1.5.4 Safety warning signs

When personnel perform routine maintenance and inspection on ECO-E215WS, in order to prevent misoperation or accidents caused by irrelevant personnel approaching, please comply with the following requirements:

- Set up obvious warning signs at the live location of ECO-E215WS to prevent dangerous accidents caused by misoperation.
- Erect warning signs or set up safety warning tapes near the installation area.

1.5.5 Battery protection signs

	<p>This sign indicates a high voltage hazard and may cause electrical hazards if touched.</p>
	<p>This sign indicates that this is the protective earthing (PE) terminal, which needs to be firmly grounded to ensure the safety of personnel.</p>

1.5.6 Equipment installation environment requirements

- It is strictly prohibited to stack flammable, explosive and other dangerous items around ECO-E215WS.
- The installation location of ECO-E215WS should meet moisture-proof and other requirements.
- The intrusion of moisture may damage the battery system. To ensure the normal and safe operation of the system, please pay attention to the ambient humidity when performing routine maintenance and inspection.

1.5.7 product end-of-life

When the battery system gets end-of-life, it cannot be disposed of as regular waste. Please contact the relevant authorized recycling agency.

2. Product description

2.1 System Overview

ECO-E215WS is a C&I ESS cabinet product independent-developed and produced by Elecnova. This product adopts the All-In-One integrated design concept and combines LFP battery system, BMS, PCS, fire safety devices, EMS, air-cooled HVAC and other equipment components are installed in standard ESS cabinets. This ESS cabinet has the characteristics of energy saving, small footprint, high energy density, strong environmental adaptability, fast on-site installation, grid-friendly access, and flexible capacity expansion.

The ECO-E215WS can be directly interconnected with the ESS-Cloud platform to perform power load response and energy arbitrage based on local grid electricity tariff policies to obtain the best economic benefits. The physical appearance of the product and the layout inside the cabinet can be seen in Figure 2-1 and Figure 2-2.



Figure 2-1 ECO-E215WS physical picture

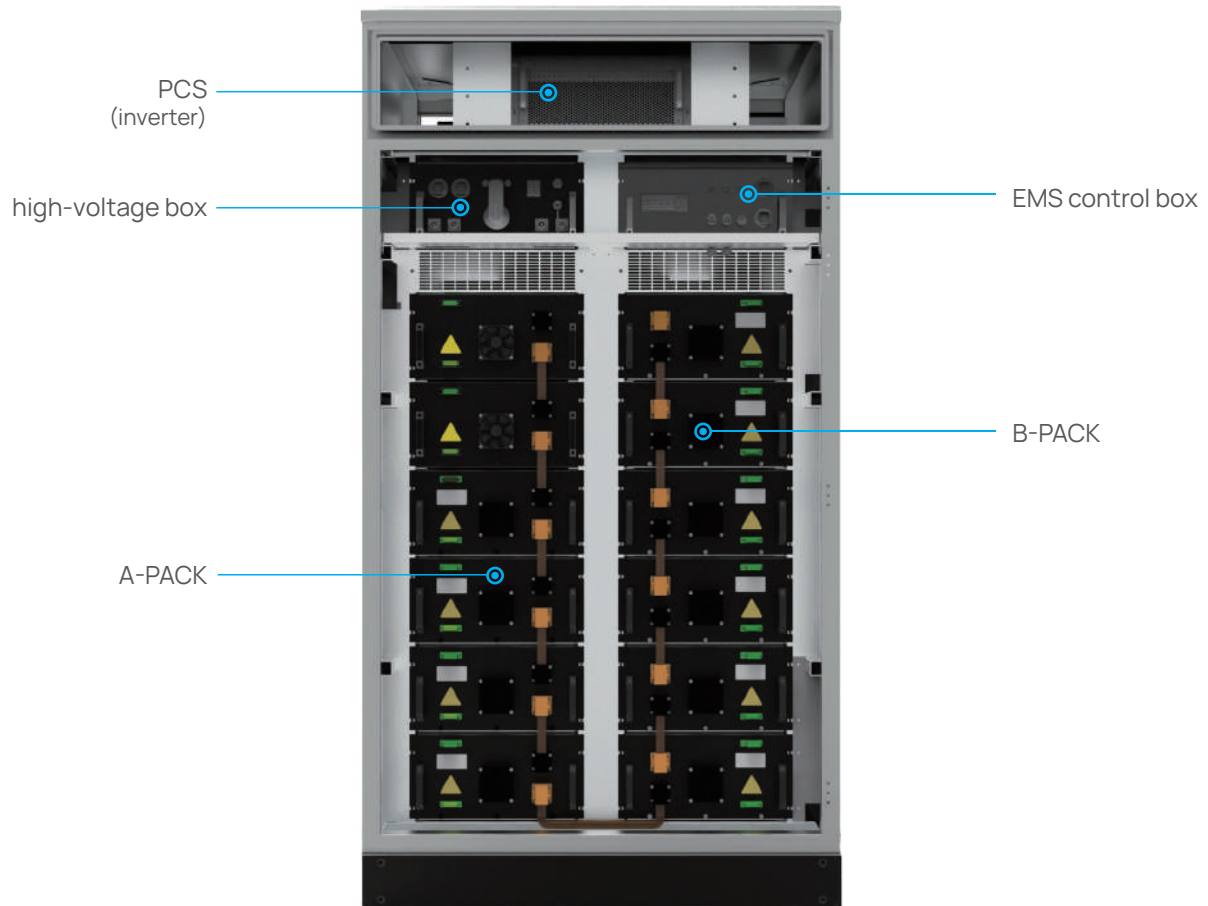

Figure 2-2 ECO-E215WS internal layout

Product features:

- Cabinet protection level IP 54, supports outdoor and indoor multi-scenario installation.
- Fire warning + fully immersive gas fire extinguishing
- Dual power supply design, supports black start of ESS cabinet.
- High charge/discharge cycle efficiency, releasing more power with good profit.
- Flexible installation according to site requirements.
- On-site rapid grid connection and commissioning.
- Supports flexible capacity expansion and parallelization of multiple units.
- Support remote cloud platform access and operation and maintenance management, unattended.

Item	Description	Remark
Product model	ECO-E215WS	
DC		
Cell type	LFP 280Ah	
System grouping	1P240S	
Rated energy	215.04kWh	100%DOD, 25°C, 0.5P
Rated capacity	280Ah	
Rated voltage	768V	
Recommended voltage range	DC 672-864V	Individual cell voltage 2.8v~3.6v
AC		
Rated output power	100kW	
Max. power	110 kW (continuous 1 min)	
Nominal voltage	400 Vac /3P+N+ PE	
Nominal frequency	50Hz / 60Hz	
THDi	< 3%	
DC component	< 0.5% I _{pn}	
Power factor	-0.98 lagging ~ 0.98 leading	
General		
System efficiency	≥ 89%	Auxiliary power excluded
Charge/discharge rate	0.5P	constant power
DoD	95%DOD	
Cycle life	≥ 8000 times (25±2°C)	25±2°C, 0.5P, 95% DOD rated operating conditions
Ingress rating	IP55	
Cooling	forced air cooling	
Operating temperature	-25 ~ 55°C	
Humidity	0 ~ 95% RH, no-condensing	
Altitude	≤ 2000m	Derating above 2000m
Dimension(W*D*H)	1250*1300*2400mm	
Weight	2500kg	
Fire safety	Smoke/temperature detection + immersive gas(aerosol)	
Connectivity	Ethernet/RS485	
Compliance	GB/T 36276, GB/T 34120, GB/T 34131, UN38.3, IEC62619, UL1973, UL9540, and CE-EMC	

2.3 System diagram

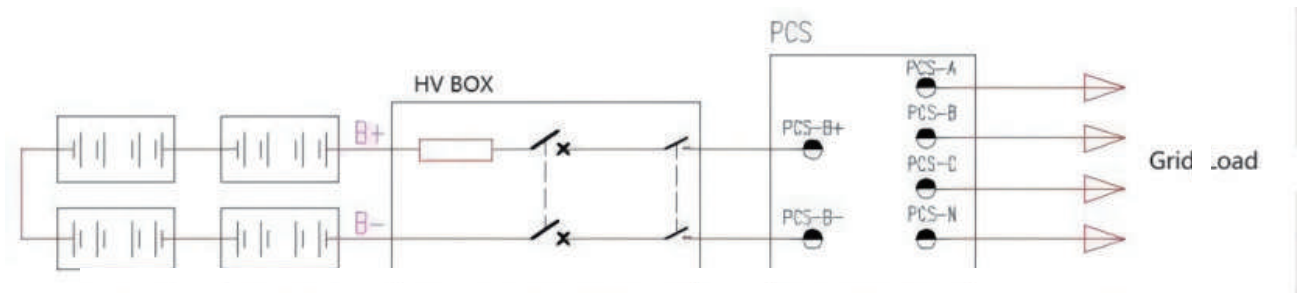

Figure 2-3 ECO-E215WS main circuit

Work mode

Grid-tied operation mode

The AC side of ECO-E215WS is connected to the power grid, and the DC side is internally connected battery. It can be applied such application scenarios as power expansion, PV plus EV charging with ESS, peak shaving, demand management, power quality management. According to the selected grid-tied PQ operating mode, which can perform constant power, constant current and constant voltage charging and discharging operations on lithium batteries.

Off-grid operation mode

The DC side of ECO-E215WS is connected to battery. When the system is running off-grid or used as black start power, ECO-E215WS operates with VF Mode. It outputs a fixed frequency and effective three-phase AC voltage to achieve continuous power supply to the AC side load. This can be applied to application scenarios such as micro-grids in islands, remote areas or backup power supplies for important loads.

2.4 Communication control

ECO-E215WS adopts a three-level architecture communication system. One of the first levels is the BMU slave control device of the BMS, responsible for PACK voltage, NTC temperature and other signal acquisition and battery balancing management. The second level is the BCU main control device of the BMS, responsible for the BMU signal collection and processing of the entire energy storage cabinet, the realization of charge and discharge control and threshold protection, and the formulation and execution of thermal management strategies. The third level is the EMS control system, which is the control brain of ECO-E215WS. It realizes the collection, monitoring, processing and control of the BMS, PCS, air conditioning, fire protection, status and other signals of the entire cabinet.

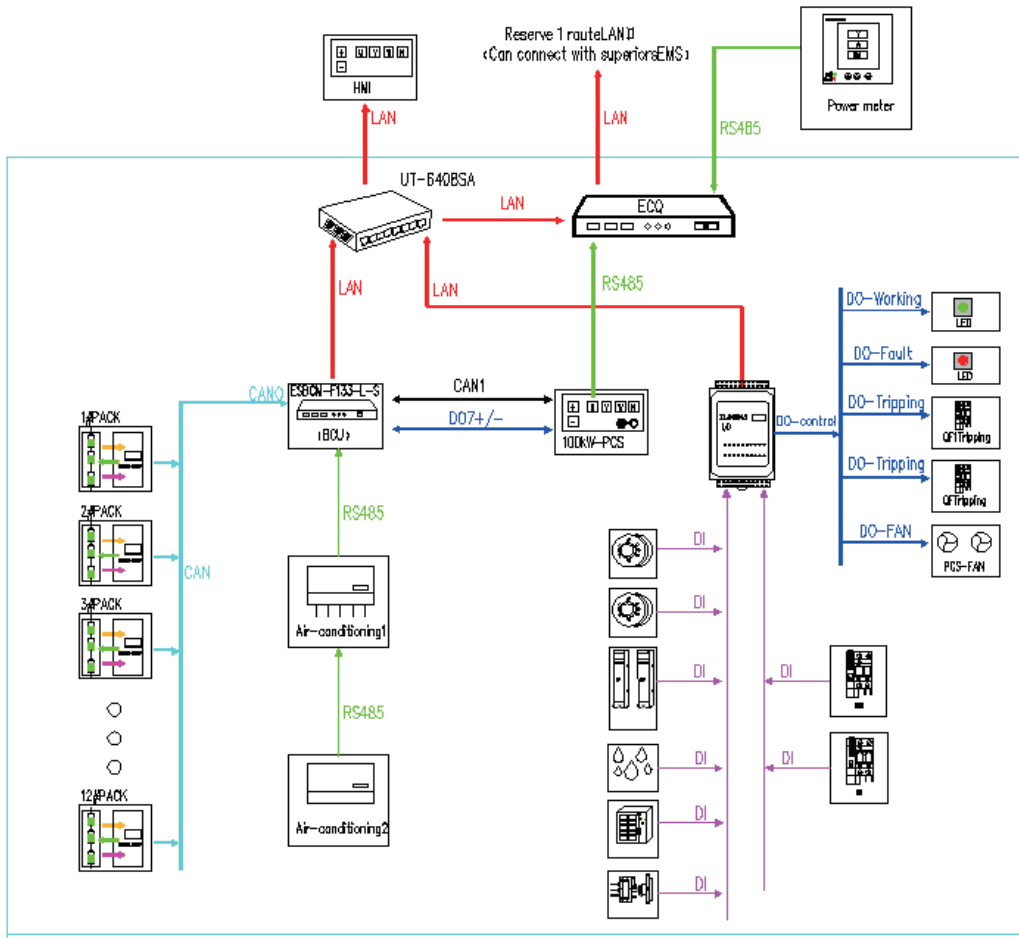

Figure 2-4 ECO-E215WS communication architecture

2.5 Port description

2.5.1 A- PACK Port description

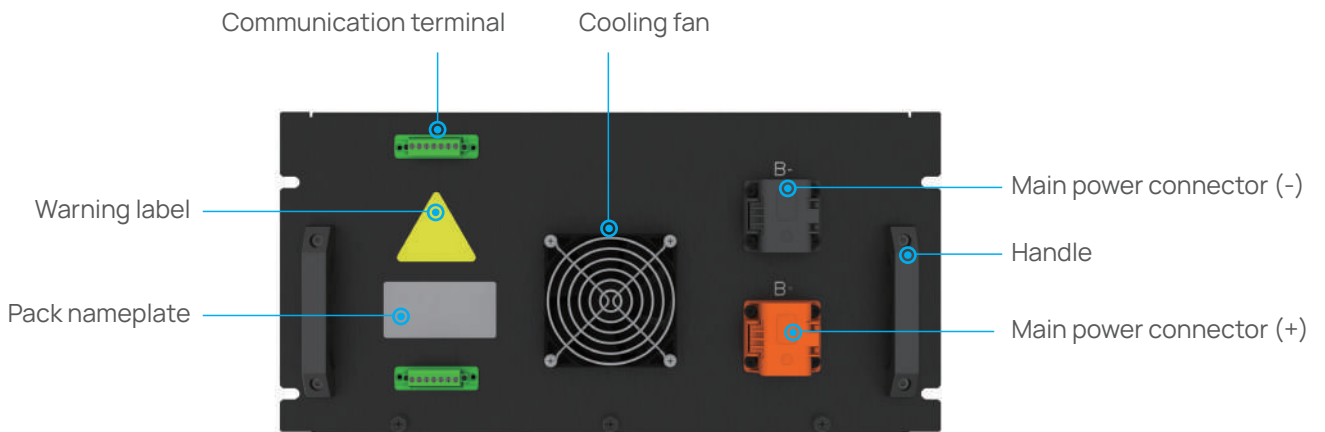

Figure 2-5 A- PACK Panel

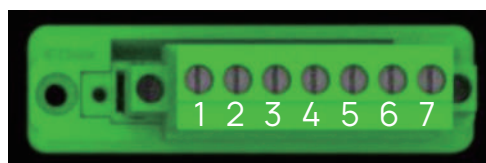

Figure 2-6 7P plug

Plug	Pin No.	Pin Def.	Function
Comm IN	1	2V-	External 24V power supply
	2	2V+	External 24V power supply
	3	CAN0L	BMS internal communication CAN0L
	4	CAN0H	BMS internal communication CAN0H
	5	I01	BMS address automatic allocation
	6	1V-	External 24V power supply
	7	1V+	External 24V power supply
Comm OUT	1	1V+	External 24V power supply
	2	1V-	External 24V power supply
	3	I02	BMS address automatic allocation
	4	CAN0H	BMS internal communication CAN0H
	5	CAN0L	BMS internal communication CAN0L
	6	2V+	External 24V power supply
	7	2V-	External 24V power supply

2.5.2 B-PACK Port description

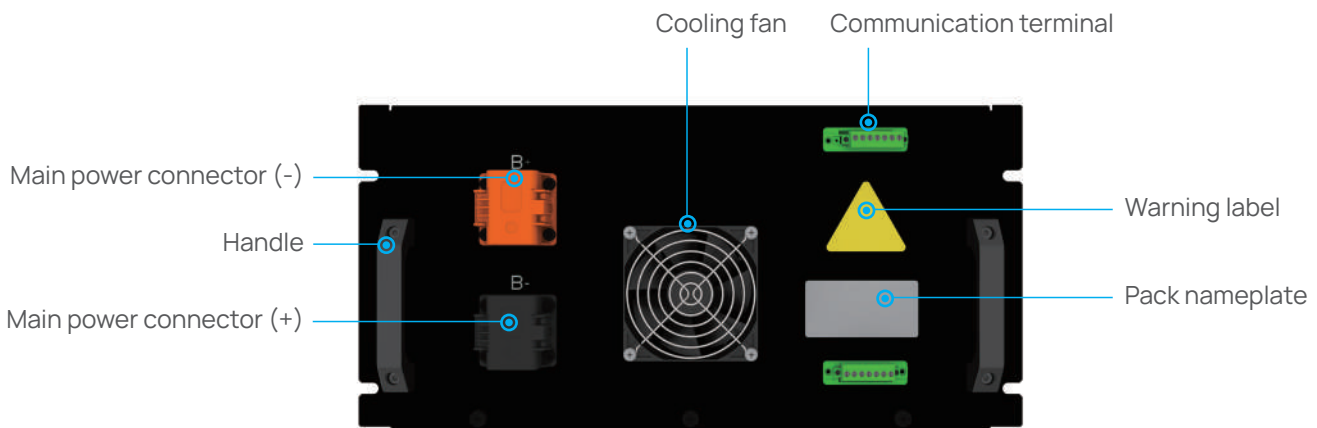

Figure 2-5 B- PACK Panel

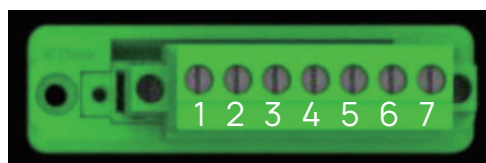

Figure 2-6 7P plug

Plug	Pin No.	Pin Def.	Function
Comm IN	1	2V-	External 24V power supply
	2	2V+	External 24V power supply
	3	CAN0L	BMS internal communication CAN0L
	4	CAN0H	BMS internal communication CAN0H
	5	I01	BMS address automatic allocation
	6	1V-	External 24V power supply
	7	1V+	External 24V power supply
Comm OUT	1	1V+	External 24V power supply
	2	1V-	External 24V power supply
	3	I02	BMS address automatic allocation
	4	CAN0H	BMS internal communication CAN0H
	5	CAN0L	BMS internal communication CAN0L
	6	2V+	External 24V power supply
	7	2V-	External 24V power supply

2.5.3 High-voltage box port description

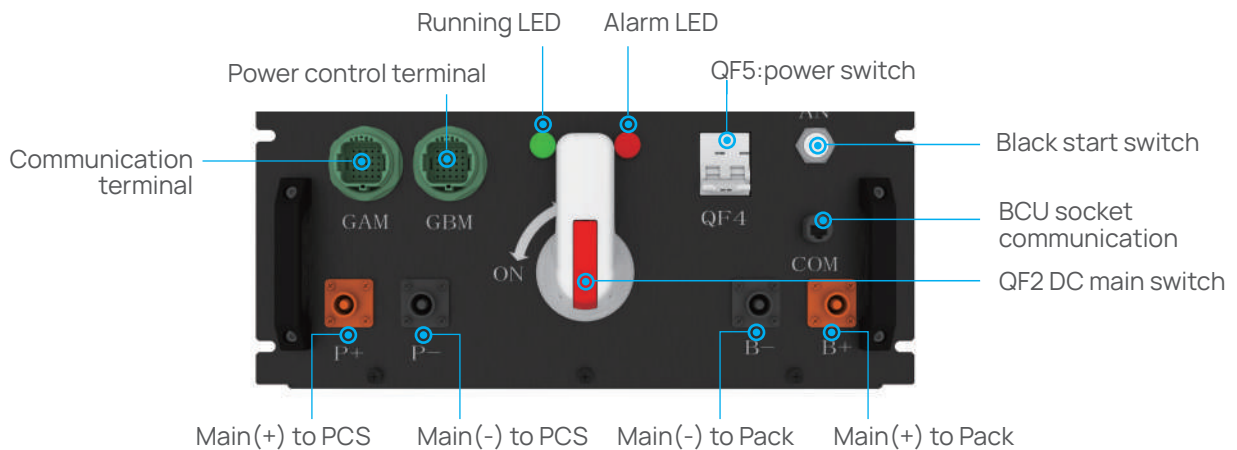

Figure 2-9 high-voltage box panel

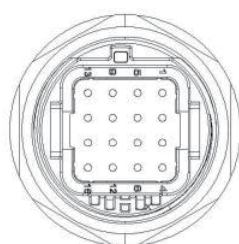

Figure 2-10 GAM, GBM plug

Plug	Pin No.	Pin Def.	Function
GAM	1	1V+	BMU power supply
	2	1V-	BMU power supply
	3	I01	BMU address allocation
	4	CAN0H	BMS internal communication CAN0H
	5	CAN0L	BMS internal communication CAN0L
	6	2V+	BMU power supply
	7	2V-	BMU power supply
	8	NA	/
	9	NA	/
	10	NA	/
	11	NA	/
	12	NA	/
	13	KT-485A	Air-conditioning 485 communication
	14	KT-485B	Air-conditioning 485 communication
	15	CAN2H	PC debugging communication
	16	CAN2L	PC debugging communication
GBM	1	CAN1H	PCS communication
	2	CAN1L	PCS communication
	3	D07+	PCS normal-open dry contact
	4	D07-	PCS normal-open dry contact
	5	DI4H	Fire sprinkler feedback
	6	DI4H-V+	Fire sprinkler feedback
	7	5V+	Cabinet black-start power indicator
	8	HW-L1	Cabinet black-start power indicator
	9	NA	/
	10	3V+	Internal 24V components power supply
	11	3V-	Internal 24V components power supply
	12	DI5L	QF3(AC220V) power supply normal-open signal
	13	DI5L-V-	QF3(AC220V) power supply normal-open signal
	14	L1	220V power input
	15	N1	220V power input
	16	PE	PC debugging communication

2.5.4 High-voltage box port description

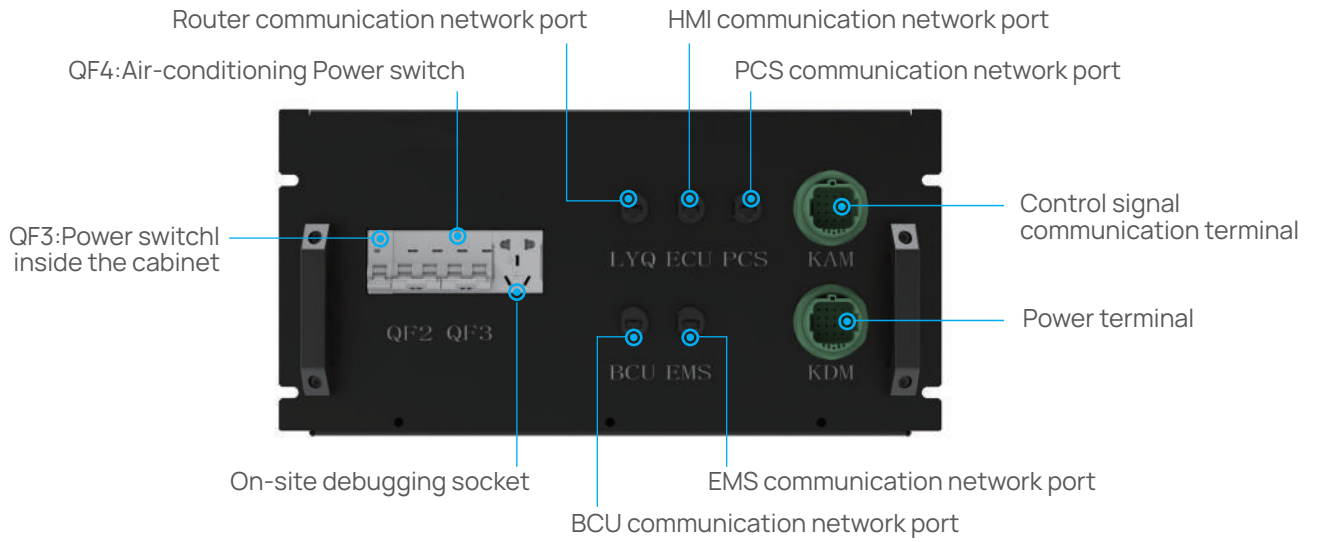

Figure 2-11 Control box panel

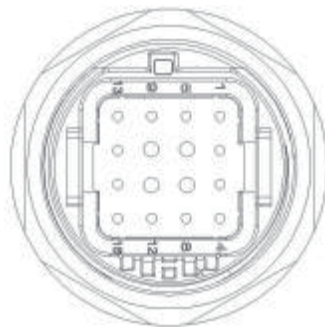

Figure 2-12 KDM plug

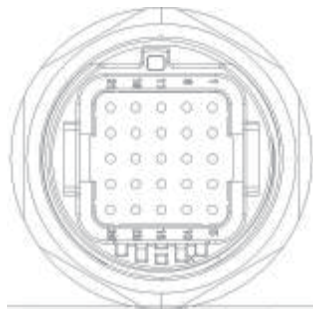

Figure 2-13 KAM plug

Plug	Pin No.	Pin Def.	Function
KDM	1	4V+	Power supply in control box
	2	4V-	Power supply in control box
	3	DO4+	Power supply switch trip of poc cabinet corresponding to ECO-E215WS
	4	DO4-	Power supply switch trip of poc cabinet corresponding to ECO-E215WS
	5	DO5+	Main power supply switch trip of poc cabinet
	6	KL	1# air-conditioning power supply
	7	KN	1# air-conditioning power supply
	8	PE	1# air-conditioning earthing
	9	DO5-	Main power supply switch trip of PoC cabinet
	10	2KL	2# air-conditioning power supply
	11	2KN	2# air-conditioning power supply
	12	PE	2# air-conditioning earthing
	13	KA2:A2	Emergency stop button trip QF3
	14	6V-	Emergency stop button trip QF3
	15	KA2:A2	Fire sprinkler trip QF3
	16	6V-	Fire sprinkler trip QF3
KAM	1	SNO	Immersion signal feedback
	2	YNO	Smoke detection signal feedback
	3	WNO	Temperature detection signal feedback
	4	DI4	Sprinkling signal feedback
	5	MNC	Access control signal feedback
	6	DI6	Emergency stop signal feedback
	7	DI7	Power supply switch trip signal feedback of poc cabinet corresponding to ECO-E215WS
	8	GND	I/O signal common terminal
	9	HW-L1	Cabinet power indicator
	10	HG-L1	Cabinet operation indicator
	11	HR-L1	Cabinet fault indicator
	12	5V-	Indicator power supply 24V-
	13	485A2	Meter communication
	14	485B2	Meter communication
	15	485A3	PCS communication
	16	485B3	PCS communication

Plug	Pin No.	Pin Def.	Function
KAM	17	DI8	Main power supply switch trip signal feedback of PoC cabinet
	18	NA	/
	19	KA7-FS	PCS fan power supply
	20	7V-	PCS fan power supply
	21	NA	/
	22	5V+	Cabinet black start power indicator
	23	HW-L1	Cabinet black start power indicator
	24	KA1:24	QF3(AC220V) power supply normal-open signal feedback
	25	KA1:21	QF3(AC220V) power supply normal-open signal feedback

2.5.4 High-voltage box port description

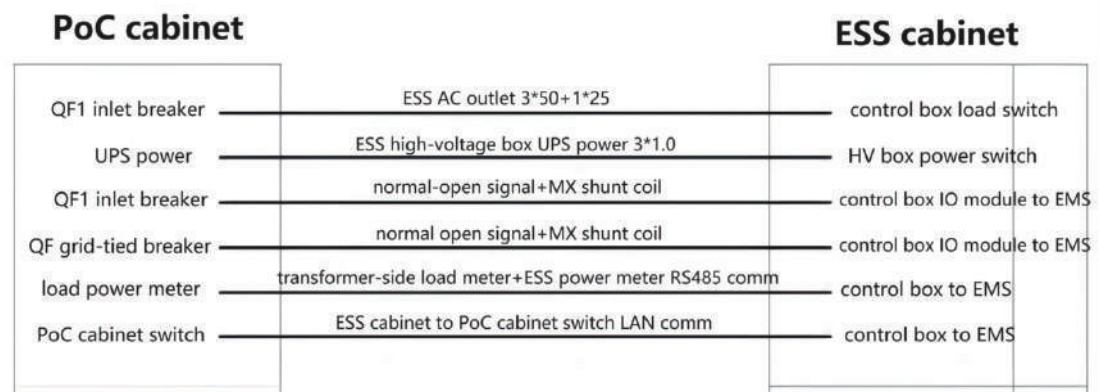

Figure 2-14 External interface diagram (see installation manual for details)
(Specific projects are subject to actual wiring)

2.6 PCS

2.6.1 PCS Introduction

PCS, also known as bidirectional converter, is a device that realizes bidirectional conversion of electrical energy. It can invert the DC power of the battery into AC power and transmit it to the power grid or use it for AC loads; it can also rectify the AC power of the power grid into DC power to charge the battery.

2.6.2 PCS System diagram

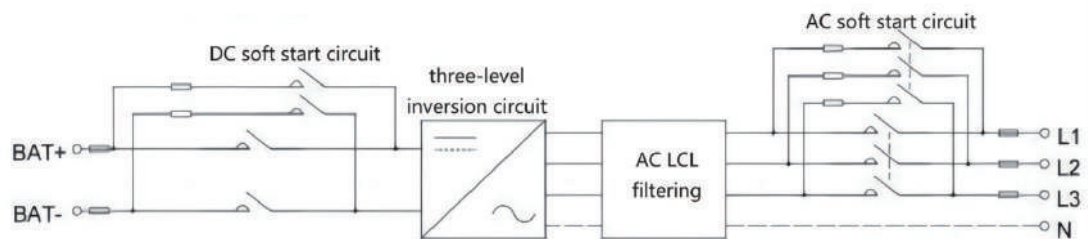

Figure 2-15 PCS diagram

2.6.3 PCS parameter

Item	Description	Remark
DC		
Rated power	100kW	
Number of inlets	1	
Max. Input current	170A	
Voltage range	672~950V	
Voltage stabilization accuracy	$\leq \pm 2\%$	
Current stabilization accuracy	$\leq \pm 5\%$	
Voltage limiting	Support	
Current limiting	Support	
AC		
Rated output power	100kW	
Rated output current	145A	
Wiring	3-phase-4-wire	
Isolation	Non-transformer	
Power factor	-0.99 lagging ~ 0.99 leading	
Rated voltage	AC 400V/220V	
Voltage range	400V(-20%~15%)	
Rated frequency	50	
Frequency range	50 \pm 5Hz continuous	
Switching time	< 100ms	
Protection		
DC-side protection	Isolating switch or fuse bank	
DC-side control	DC contactor	
AC-side protection	Circuit breaker or fuse	
AC-side control	AC relay	
Short circuit protection	Support	
AC phases sequence protection	Support	
Comm fault protection	Support	
Anti-islanding protection	$\leq 2s$	
DC overvoltage protection	Support	
AC overvoltage protection	Support	
Reverse polarity protection	Support	
Overheat protection	Support	
LVRT	With fault-ride-through	

Item	Description	Remark
Other		
Dimensions(W*D*H)	544*670*270mm	
Structure & ventilation	Rear maintenance, front air-in/rear air-out	
Weight	50kg	
Cooling	Forced air cooling	
Overload	110%	Continuous, (@ambient temperature \leq 35 $^{\circ}$ C)
	120%	60 seconds
Standby loss	\leq 0.2% rated power	
No-load loss	\leq 0.5% rated power	
Max. efficiency	\geq 98%	
Connectivity	EMS Communication: RS 485 interface, Communication protocol: MODBUS - RTU ; BMS Communication: CAN	
Environment		
Installation	Inside cabinet	
Ingress rating	IP20	
Temperature	-20 $^{\circ}$ C ~+50 $^{\circ}$ C	
Humidity	0% ~ 95%RH	Non-condensing
Altitude	2000m	Derating above 2000m

2.6.4 PCS Panel layout

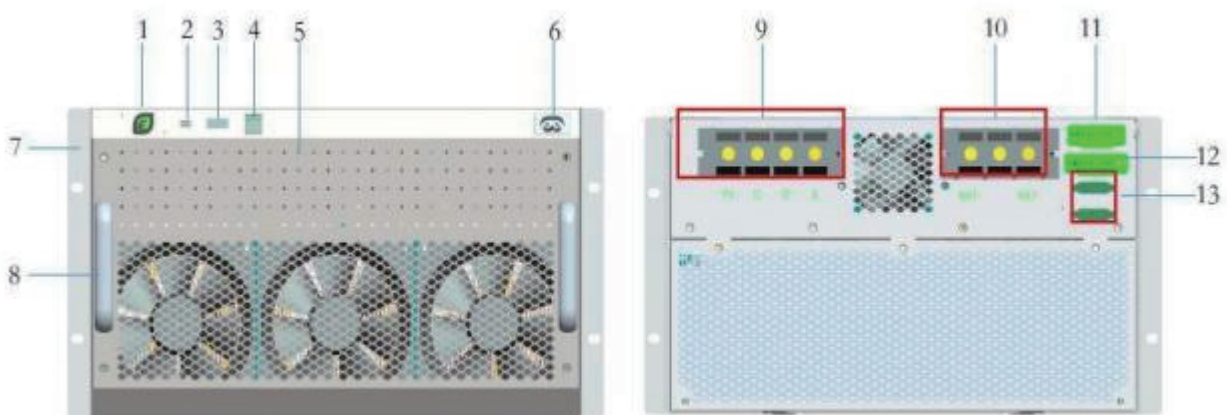

Figure 2-16 PCS Panel layout

No.	Item	Description
1	Indicator	Continuous green when running; Fast flash green at 0.5s intervals when standby (0kw operation); Slow flash green at 1s intervals when power off and no fault; Continuous red when fault
2	ETH/LOCAL	Ethernet/local debugging switch; Right dial LOCAL for local debugging; Left dial ETH Ethernet (reserved)
3	(IO) 6-bit DIP switch	Bits 1-2 are CAN Communication matching resistor access; Bits 3-6 is the module address setting (binary) - the 6th bit is the lowest bit (from right to left)
4	TEST debugging network port	Debugging communication port (internal use only)
5	Vents	Air duct vents, front air-in and rear air-out
6	220V Power interface	220Vac input (internal use only)
7	Fixing bracket	Fixing brackets are installed on the left and right sides of the module for connection to the cabinet.
8	Handle	Drawer module handles, not for load-bearing purposes
9	AC interface	AC terminal wiring
10	DC interface	DC terminal wiring
11	Grid current sampling interface	A/B/C three-phase current feeder-in and feed-out interface (reserved for 105 kW equipment)
12	Grid voltage sampling interface	A/B/C/N grid voltage sampling input interface (reserved for 105 kW equipment)
13	External comm plug	COM (26-pin signal) signal plug

2.6.5 PCS External communication terminal definition



Figure 2-17 PCS external comm plug

No.	Pin No.	Pin Def.	Function
1	10	EMS_485A	EMS communication
2	19	EMS_485B	
3	1	HMI_485A	HMI communication
4	11	HMI_485B	
5	20	ETH_485A	Communications (reserved)
6	2	ETH_485B	

No.	Pin No.	Pin Def.	Function
7	12	CAN_1L	CAN Parallel
8	21	CAN_1H	
9	3	CAN_2L	BMS communication
10	31	CAN_2H	
11	18	OP	24V+/ GND type select signal
12	5	DC 24V+ output power supply 1	DC24V Output power
13	15	DC 24V+ output power supply 2	DC24V Output power
14	14	GND - IS01	Signal common terminal 1
15	23	GND - IS02	Signal common terminal 2
16	26	EPO_ISO	Emergency stop input
17	25	FIRE_ALARM	Fire alarm input signal
18	24	LED_RUN	Led run signal
19	6	LED_FLT	Led fault signal
20	16	SPD_ALARM	Lightning protection input signal
21	8	DO_ISO	DO1 digital output (reserved)
22	7	DI1_ISO	DI1 digital input signal (BMS to PCS fault shutdown alarm)
23	17	DI2_ISO	DI2 digital input signal (reserved)
24	4	INV_SYNC	Internal power frequency synchronization signal
25	22	CARRIER SYNC	Internal carrier synchronization signal
26	9	GND-ISO4	DO digital output (STS spare)

2.7 Fire suppression system

2.7.1 System working principle

When a fire occurs due to thermal runaway of the cells, the smoke detector first outputs an electrical signal, activates the audible and visual alarm to notify personnel to take action, the temperature detector outputs an electrical signal, activates the fire suppression device, implements fire extinguishing, and simultaneously outputs feedback signals to the BMS , notify personnel to handle it in a timely manner.

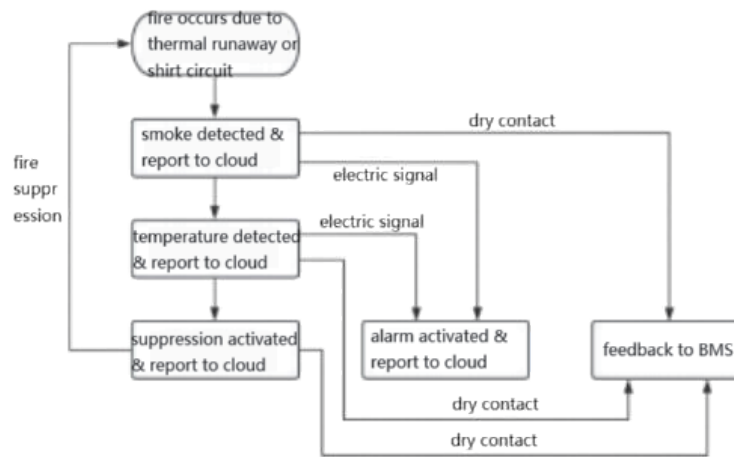

Figure 2-18 ECO-E215WS fire suppression logic block diagram

2.7.2 System composition

2.7.2.1 Aerosol fire suppression device

Product description:

QRR0.3G/S-Q hot aerosol fire suppression device is a new high-efficiency and environment-friendly fire-suppression product that has the world's advanced level benefiting mankind and born under the background of the international Montreal Agreement and worldwide increasing awareness of environmental protection. It is an ideal substitute for Halon fire suppression devices and is suitable for relatively closed spaces such as distribution cabinets.

Working principle:

When a fire occurs, the aerosol generator will be activated when thermal wire is ignited by electric start signal or an open flame. The heat released by the aerosol generator through the oxidation-reduction reaction decomposes the chemical coolant to achieve aerosol generator and coolant to participate in fire extinguishing together.

2.7.2.2 Audible and visual alarm

Product description:

The audible and visual alarm is a device installed on site that can emit sound and light alarms. When the alarm receives a signal, it emits a strong sound and light alarm signal to alert on-site personnel to pay attention.

2.7.2.3 Point-type photoelectric smoke detector

Product description:

Point-type photoelectric smoke detectors have specially-designed EMC capabilities and stable & reliable performance. They are suitable for smoke detection in rail transit, communication stations, shopping malls, warehouses, motor rooms, distribution cabinets, energy storage cabinets and other civil and industrial places. The detector has the characteristics of high sensitivity, stability and reliability, low power consumption, fashion-design and durable, and easy to use.

2.7.2.4 Point-type thermal detector

Product description:

Point-type photoelectric thermal detectors have specially-designed EMC capabilities and stable & reliable performance. They are suitable for temperature detection in rail transit, communication stations, shopping malls, warehouses, motor rooms, distribution cabinets, energy storage cabinets and other civil and industrial places. The detector has the characteristics of high sensitivity, stability and reliability, low power consumption, fashion-design and durable, and easy to use.

3. Equipment operation

3.1 Hazards

3.1.1 Electric shock hazard

	<p>Personnel will be exposed to voltages up to 864 VDC from ECO-E215WS battery pack, and there is also the possibility of low- and medium-voltage AC exposure. Arc flash and electric shock hazards are common at ESS sites. Elecnova encourages full compliance with the practices and procedures specified in NFPA 70E, including the use of personal protective equipment (PPE), to adequately mitigate hazards identified in site-specific arc flash studies. Emergency personnel should rely on standard operating procedures (SOPs) to respond to incidents at power generation facilities.</p>
---	---



3.1.2 Fire and explosion hazards





	<p>ECO-E215WS contain flammable materials, ignition sources and enough oxygen to cause a fire to spread. If not properly mitigated, fire and other sources of extreme heat can cause cascading thermal runaway of the battery and the release of flammable gases. If these flammable gases are present in sufficient density, there is a risk of explosion. If a fire alarm or other indication of thermal runaway occurs at the energy storage cabinet or ESS site, first responders are advised to maintain a safe perimeter until entry to the ESS site can be verified to be safe in accordance with the site-specific Emergency Response Plan (ERP) and SOP.</p>
--	---

3.1.3 Chemical exposure hazards

	<p>ECO-E215WS contain flammable materials, ignition sources and enough oxygen to cause a fire to spread. If not properly mitigated, fire and other sources of extreme heat can cause cascading thermal runaway of the battery and the release of flammable gases. If these flammable gases are present in sufficient density, there is a risk of explosion. If a fire alarm or other indication of thermal runaway occurs at the energy storage cabinet or ESS site, first responders are advised to maintain a safe perimeter until entry to the ESS site can be verified to be safe in accordance with the site-specific Emergency Response Plan (ERP) and SOP.</p>
---	---

3.2 Operation precautions

	<p>The battery cannot be powered off. The shutdown sequence described below only isolates the battery and associated hazardous voltages. Personnel must use extreme caution and wear appropriate PPE at all times.</p>
	<p>The complete ESS shutdown sequence will vary based on project-specific design. Always consult site-specific schematics and manuals to ensure proper isolation of electrical equipment.</p>

 <p>WARNING</p>	<p>All personnel operating ECO-E215WS should be properly trained and qualified. Personnel are expected to read and understand all manuals and project documents and comply with their requirements and instructions.</p>
 <p>WARNING</p>	<p>Turning off thermal management and communication systems for extended periods of time can result in equipment damage and the inability to detect and communicate fault conditions.</p>
 <p>CAUTION</p>	<p>Disconnecting the BMS contactor under load may damage the BMS of the integrated energy storage cabinet, and direct power failure may cause the main positive and negative contactors to stick. Only use the emergency stop button in emergency situations.</p>
 <p>CAUTION</p>	<p>Do not start xECO-E215WS until the system has been fully commissioned and inspected by Elecnova on-site technicians, or before all required scheduled maintenance has been performed.</p>
 <p>CAUTION</p>	<p>Please do not modify or alter this manual without Elecnova's written permission.</p>

3.3 Cabinet panel description

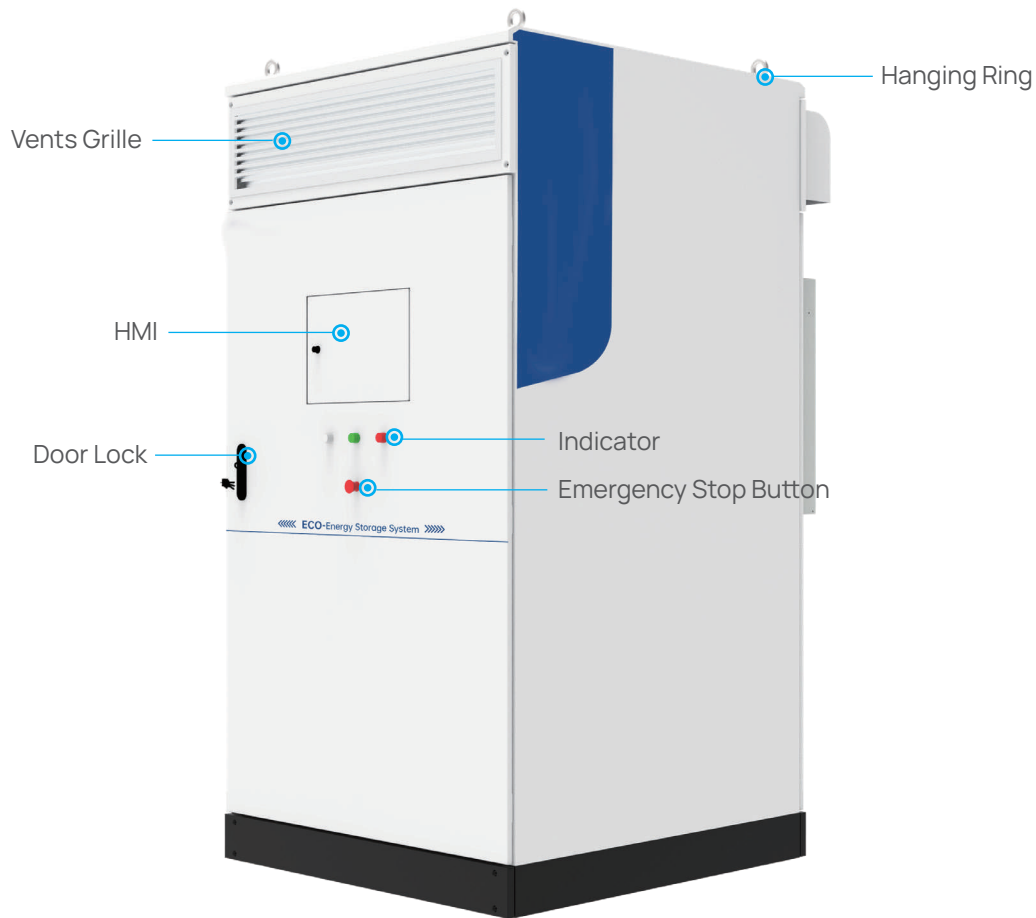

Figure 3-1 ECO-E215WS Front View

No.	Item	Qty.	Remark
1	Hanging ring	4	Lifting cabinet
2	HMI	1	Onsite parameters monitoring
3	Indicator (white)	1	Power indication (See indicator status table for details)
4	Indicator (green)	1	Run indication (See indicator status table for details)
5	Indicator (red)	1	Fault indication (See indicator status table for details)
6	Emergency stop button	1	Equipment emergency stop
7	Door lock	1	
8	Vents grille	1	

Indicator status table

Indicator	Operation condition	Status	Remark
Power (white)	AC 220V main power supply is powered on and the power is controlled. QF2 Close	on	
	DC/DC power on, 24V Control power on. QF5 Close	on	
	AC 220V and DC / DC power supplies are powered on at the same time, means QF2 and QF5 also close	on	
	AC 220V or DC/DC power supply is not powered on, i.e. QF2 and QF5 are open	off	
Run (green)	charging status of ECO-E215WS, charging power $\geq 5\text{kW}$	on	
	Discharging status of ECO-E215WS, discharging power $\geq 2.5\text{kW}$	on	
	Not charging or discharging	off	
Fault (red)	Smoke detection signal action	on	
	Temperature detection signal action	on	
	Aerosol spray signal feedback	on	
	The liquid level detected by immersion sensor reaches the alarm value	on	
	Discharging power $\geq 5\text{kW}$ and the door is open (NC signal)	on	
	BMS charge/discharge 3rd level alarm (soc alarm excluded)	on	
	PCS total fault bit (EMS Display the fault code and confirm the fault type): 1.grid peak value over-voltage fault 4.grid RMS value over-voltage fault 5.grid RMS value under-voltage fault 6.branch 1 peak value over-current fault 7.branch 2 peak value over-current fault 8.branch 1 RMS value over-current fault 9.branch 2 RMS value over-current fault 10.DC fuse failure 11.emergency stop failure 12.DC over-voltage fault 13.DC under-voltage fault 14.over deviation fault between positive and negative busbars 15.DC over-current fault 16.battery short circuit fault 17.grid over-frequency fault 18.grid under-frequency fault 19.grid phase sequence fault 20.grid phase loss fault 21.battery polarity reverse fault, reserved (for parallel use)	on	PCS fault bit

Indicator	Operation condition	Status	Remark
	22.module external CAN comm fail 23.EEPROM Read and write failure 24.Module IGBT over-temperature failure 25.hardware over-current fault 26.zero-sequence over circulation fault 27.grid transient over-current fault 28.AC pre-charge failure 29.DC pre-charge failure 30.high voltage closing failure 31.contactor status, communication failure with BMS, communication failure with EMS (running light is on, PCS is working)	on	PCS fault bit
Fault (red)	BMS total fault bit (EMS Display the fault code and confirm the fault type): 1.PACK discharge over-current 2nd level alarm 2.PACK charge over-current 2nd level alarm 3.PACK insulation 2nd level alarm 4.cell charge over-heat 2nd level alarm 5.cell charge under-heat 2nd level alarm 6.over cell voltage difference 2nd level alarm 7.over cell temperature difference 2nd level alarm 8.DI1, DI2, DI3, DI4, DI5, DI6, DI7, DI8 fault; 9.internal comm lost 10.cell voltage sampling abnormal 11.cell temperature sampling abnormal 12.battery limit fault 13.software version parameters inconsistent 14.comm fault to PCS 15.PC forced control debugging mode 16.CAN Hall sensor failure 17.CAN Hall sensor comm failure 18.hardware self-test abnormal 19.balancing failure 20.comm fault to EMS 21.cell discharge over-heat 2nd level alarm 22.cell discharge under-heat 2nd level alarm 23.high temperature rise rate 2nd level alarm 24.comm fault to A/C	on	BMS fault bit

Indicator	Operation condition	Status	Remark
Fault (red)	EMS Total fault bit 1. IO module fault; 2. 4G router fault; 3. Industrial computer body fault; 4. Industrial switch fault; 5. IO module communication fault; 6. 4G router communication fault; 7. Industrial switch communication fault; 8. Fault in communication with BMS (operation light on, PCS working); 9. Fault in communication with PCS (operation light on, PCS working); 10. Electricity meter communication fault (operation light on, PCS working)	on	EMS fault bit
	Fully-charged or empty state of battery, which does not trigger the 3rd level alarm	off	Fully-charged or empty state
	1st/2nd alarm of 215kWh ESS cabinet BMS	off	Minor fault state of BMS
	Non-fault state of 215kWh ESS cabinet	off	Non-fault state

3.4 Connection and Power-on of ECO-E215WS

3.4.1 Cable Connection

Please refer to the installation manual.

3.4.2 Power-on Operation of ECO-E215WS

After the grid-tied cabinet is turned on and the mains power supply is connected to ECO-E215WS, please close the switches QF1, QF2, QF5, QF3, and QF4 sequentially, and ensure that the PCS is in a shutdown state after being powered on (Please determine the PCS state on HMI or WEB), and the BMS closes the main negative and main positive contactors normally. As a result, the operation indicator light for ECO-E215WS will come on, and the ECO-E215WS will be powered on.

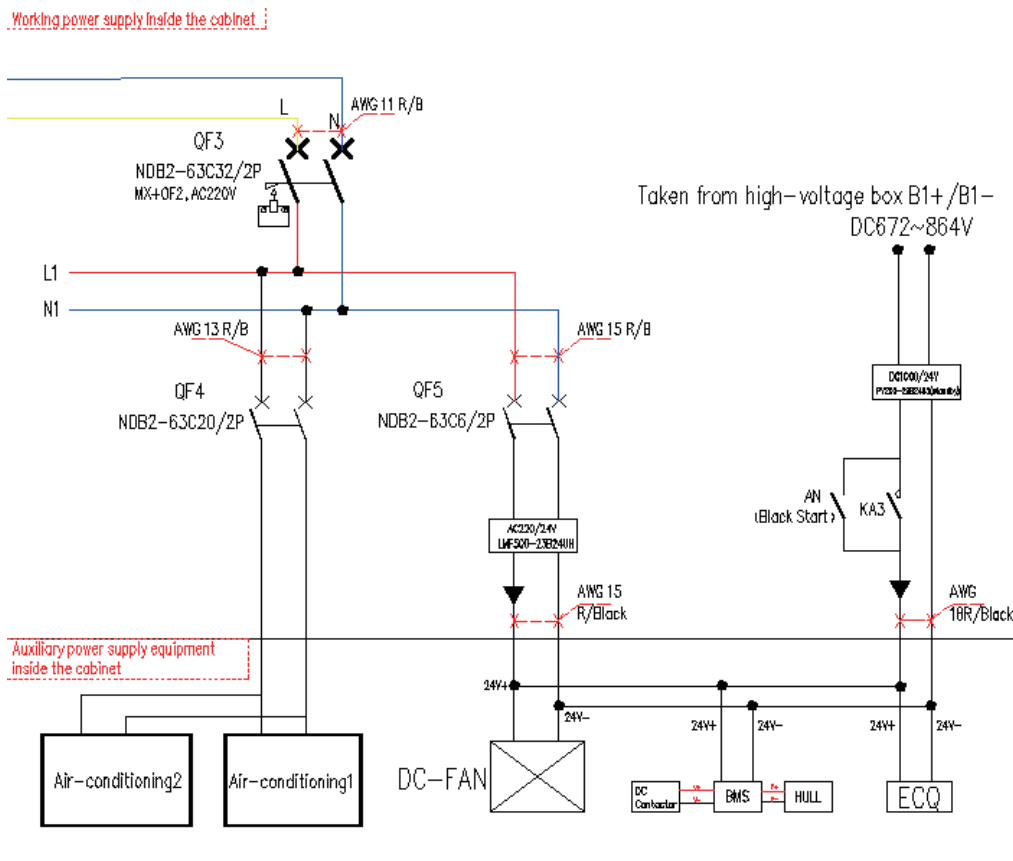

Figure 3-2 Wiring Diagram for Working Power Supply of ECO-E215WS

Note: During on-site operation and maintenance, if the PCS is not in a shutdown state, it is strictly prohibited to make the BMS perform the power-on operations!!!

- (1) When QF1 is closed, the system will be powered on;
- (2) When QF2 is closed, the main positive and main negative contactors of PACK will be connected;
- (3) When QF5 is closed, the high-voltage box will be powered on. After the high-voltage box is powered on, a 24V power supply system will be led out from the high-voltage box to the terminal block for supplying power to other 24V loads. The EMS system will enter a self-check state, and will automatically close the high-voltage contactor in the high-voltage box after there are no faults. At this point, a DC high voltage will be generated at both ends of the positive and negative output poles of the battery cabinet. Afterwards, the EMS system will detect whether there is a fault in the PCS. If there is no fault, the EMS system will notify the PCS to close its main contactors. If the EMS system does not give the command, the PCS will be in the standby mode. If the EMS systems gives the power-on command, the PCS will go from standby mode to self-check mode and then to grid-tied mode;
- (4) When QF3 is closed, the 220V system inside the control box will be powered on;
- (5) When QF4 is closed, the air-cooled air conditioner will receive the power and run in standby mode.

3.5 Charging and Discharging of ECO-E215WS

After the primary circuit of the 215kWh ECO-E215WS is powered on, the EMS control system will enter the charging and discharging state (BMS detects the charging and discharging current), and the entire air-cooled ECO-E215WS will be charged and discharged. At this point, the green and white lights will come on.

3.6 Power-off Operation of ECO-E215WS

- (1) Firstly disconnect the QF2 DC load switch on the high-voltage box panel, and then disconnect the QF5 micro switch on the high-voltage box panel. As a result, the main circuit contactors in the high-voltage box will be disconnected, the green and red LED indicator lights on the high-voltage box panel will go off, and the high-voltage box will be successfully powered off.
- (2) After the power supply of the high-voltage box is disconnected, disconnect the QF4 switch on the EMS control box panel, so as to power off the air conditioning; then disconnect the QF3 switch on the EMS control and panel, so as to cut off the AC220V working power supply for ECO-E215WS. Afterwards, disconnect the QF1 switch on the rear side of EMS, so as to disconnect ECO-E215WS disconnected from the external power grid.
- (3) Observe the white LED power indicator light on the ECO-E215WS panel goes out, which indicates that ECO-E215WS is successfully powered off.

Note: Before powering off ECO-E215WS, please ensure that it has exited from the charging and discharging state, and never cut off the power supply when it is charged or discharged!!!

3.7 Operation Instructions for Upper Computer

3.7.1 Preparation before Debugging of Upper Computer

- (1) In light of the actual application scenario, find and confirm the corresponding debugging port: during the single module PACK debugging/testing phase, connect the CAN card to the CAN0 port; during the battery system debugging/testing phase, connect the CAN card to the CAN2 port of high-voltage box;
- (2) Before turning on low-voltage power supply, inspect whether the supply voltage is within the normal system voltage range. The power supply of a 12V (24V) system is generally required to be in the range of DC9-16V (DC22-32V);
- (3) Inspect the sequence of wires H and L of CAN card before turning on the low-voltage power supply, and use a multimeter to measure whether the resistance between CANH and CANL is around 60Ω after the CAN card is connected;
- (4) Before turning on the low-voltage power supply, inspect the ± wire sequence of supply voltage again;
- (5) Inspect and confirm the correspondence between the script ControlCAN.dll in the upper computer installation package and the model of CAN card;
- (6) Inspect the correspondence between the system configuration table EvbmaServer.ini and the model of CAN card, and inspect the baud rate;
- (7) Inspect whether the parameter configuration table EVBCM-Parainew.ini is consistent with the design parameters of the battery system.
- (8) List of 6 kinds of commonly-used CAN cards:



- (9) It is necessary to install the CAN driver for the computer that uses CAN software for the first time.

3.7.2 Data Viewing on Upper Computer

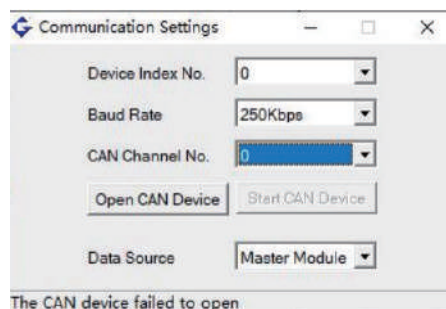



Figure 3-2 Wiring Diagram for Working Power Supply of ECO-E215WS

2.6.3 PCS parameter

	<p>When manually simulating the closing of DO on the upper computer, please confirm that the load end is in an unloaded state, and confirm the logical relationship. Unauthorized closing may lead to safety accident and system damage.</p>
	<p>Before turning on the upper computer, please confirm that other CAN software has been turned off; otherwise, software errors may occur.</p>

3.8 Operation Instructions for HMI

Please refer to the User Manual for HMI configuration screen of ECO-EMS-CLOUD energy management system.

3.9 Operation Instructions for WEB Platform

Please refer to the User Manual for web platform of ECO-EMS-CLOUD energy management system.

3.10 Operation Instructions for Mobile Application

Please refer to the user manual for mobile application of ECO-EMS-CLOUD energy management system.

4. Maintenance

4.1 Interpretation of Terms

- (1) Normally operating: The system is operating every day;
- (2) Intermittently operating: The monthly operating frequency of the system is not fixed, and it cannot be guaranteed that the system operates every day;
- (3) Long-term idle: The battery system has not been started for more than 3 consecutive months (the battery system needs to be charged until the SOC reaches 40% before lying idle).

4.2 Use Requirements for Normally-operating System

- (1) Perform the battery maintenance for the system once every twelve months, so as to prevent battery damage. Please refer to 4.5 for specific maintenance methods;
- (2) Inspect the system once every twelve months (Please refer to Annex 1), and make the inspection records properly.

4.3 Use Requirements for Intermittently-operating System

The use requirements are the same as those for normally-operating system.

4.4 Use Requirements for Long-term Idle System

- (1) Please avoid long-term storage of battery cells under the condition that the SOC is lower than 15%. If the battery is to lie idle for a long time, please turn off the power-consuming equipment in a timely manner;
- (2) Inspect the energy storage system once every three months (please refer to Annex 1), and make the inspection records properly.
- (3) Perform the battery maintenance for the system once every three months, so as to prevent battery damage. Please refer to 4.5 for specific maintenance methods;
- (4) Before the first use of the long-term idle system, please fully charge the battery system at least once, so as to restore its performance to the optimal state.

4.5 Operation Methods for Battery Maintenance

In order to ensure the long-term safe and reliable operation of your energy storage system, please carefully read and comply with the following use instructions:

Maintenance Process:

Option 1: This energy-saving option is recommended when the SOC of the battery system is at the low end.

- (1) Discharge the battery system to the cut-off condition (average individual voltage < 3.1V or minimum voltage < 2.8V), and then let it stand for 1 hour;
- (2) Automatically charge the battery system until its SOC is 100% (maximum individual voltage > 3.65V), and then let it stand for 1 hour;
- (3) Discharge the battery system until its SOC is 40%.

Option 2: This energy-saving option is recommended when the SOC of the battery system is at the high end.

- (1) Automatically charge the battery system until its SOC is 100% (maximum individual voltage > 3.65V), and then let it stand for 1 hour;
- (2) Discharge the battery system to the cut-off condition (average individual voltage < 3.1V or minimum voltage < 2.8V), and then let it stand for 1 hour;
- (3) Charge the battery system until its SOC is 40%.

5. Fault Handling of Energy Storage System

5.1 Handling Methods for Common Faults

ECO-E215WS has perfect protection functions. When abnormal operating conditions are detected, the battery system will automatically take the corresponding measures to timely ensure the safety of energy storage system and its components, and ensure the reliable operation of battery system cabinet.

The abnormal operating conditions of ECO-E215WS is divided into "warning", "minor fault", and "major fault". For a "warning", the battery system will not take any action; a "minor fault" indicates that there is a minor abnormality in the battery system cabinet; a "major fault" indicates that there is a major abnormality in the battery system cabinet. Users can view the fault details through the display interface of energy storage system and contact our after-sales service department in a timely manner.

5.2 Handling Methods for Emergency Faults

5.2.1 Fire

Step 1: Evacuate the on-site personnel to a safe place, delineate a safe isolation zone, and call the alarm number based on the on-site situations.

Step 2: To the extent that the personal safety is ensured, perform the following operations if the on-site conditions permit:

- (1) If any harness is smoking or catching fire, use a carbon dioxide or dry powder fire extinguisher to extinguish the fire.
- (2) If the energy storage battery catches fire, use a high-pressure water gun at a distance to extinguish the fire.
- (3) If you accidentally inhale thick smoke, please evacuate and seek medical advice as soon as possible.

5.2 Handling Methods for Emergency Faults

5.2.2 Water Flooding

Step 1: Regardless of whether the system is powered on or not, evacuate the on-site personnel to a safe place and delineate a safe isolation zone.

Step 2: Notify the system supplier to conduct maintenance after the water recedes.

Step 3: Be sure not to start the system until the system manufacturer determines that the system is safe.



If a fire is caused by abnormal charging or discharging, be sure to immediately cut off the power supply, and then extinguish the fire!!!

6. Warranty Statement

The warranty period shall be subject to the business contract. During the warranty period, if any component of this product is damaged or fails to meet the indicators specified in the contract due to manufacturing defects or improper design, Party B shall repair or replace the component and even improve the equipment structure for the purchaser free of charge, except for the following circumstances.

- (1) Various faults occur due to failure to use, maintain, and repair this product correctly according to the provisions of this Manual.
- (2) This product has been soaked, impacted or damaged beyond its bearing capacity.
- (3) The battery system has been modified, disassembled, and adjusted without authorization from Elecnova.
- (4) The damage is caused by the customer's handling of the fault of battery system without permission from Elecnova.
- (5) The quality problem is caused by failure to use the genuine components provided by us.
- (6) The damage is caused by the use of charging equipment that fails to comply with national standards or the improper charging operations.
- (7) Both parties shall be exempt from liability for any damage caused by force majeure factors such as earthquake, typhoon, flood, chemical pollution, lightning strike, hail, sediment, flying rock, fire, political disaster, or artificial destruction, as well as any secondary compensation arising therefrom.

7. After-sales Services

If you have any question or concern about this product, please contact us as follows:

Name: Shanghai Elecnova Energy Storage Technology Co., Ltd.

Address: No. 888, Yanling East Road, Jiangyin City, Jiangsu Province

After-sales Service Hotline: 0510-56191125

To the extent permitted by laws, Elecnova has the final interpretation right of this Manual, and reserves the right to modify this Manual without further notice.

Annex 1:

Inspection Item	Method	Yes-√ No- × N/A-O	Abnormal Record
Whether the fire extinguishing system is complete	Visual inspection		
Whether the cooling system is complete	Visual inspection		
Whether the air duct of cooling is system blocked	Visual inspection		
Whether the surface of the entire cabinet is deformed	Visual inspection		
Whether the surface of the entire cabinet is rusted or damaged	Visual inspection		
Whether there is any moisture inside the cabinet	Visual inspection		
Whether the low-voltage harness is loosened or damaged	Visual inspection		
Whether the high-voltage harness is loosened or damaged	Visual inspection		
Whether any harness interferes with the structural components	Visual inspection		
Whether the high-pressure connection is ablated	Visual inspection		
Whether the fixing bolts of structural components are loosened or missing	Visual inspection		
Whether there is any foul odor inside the cabinet	Smelling with nose		
Whether there is any irritating odor inside the cabinet	Smelling with nose		
Whether there is any burnt smell in the high-pressure connection area	Smelling with nose		
Whether the summary data are complete	Inspection on upper computer		
Whether the individual voltage data are complete	Inspection on upper computer		
Whether the individual temperature data are complete	Inspection on upper computer		
Whether there is any abnormal alarm in the alarm bar	Inspection on upper computer		

Note: If any abnormality is found during the inspection, please provide feedback in time and contact the relevant personnel for handling

All-in-one Air-cooled

ESS ECO-E215WS Cabinet Installation Manual

The release date identified in the change history for this Manual is correct. We reserve the right to modify products and documentation at any time.

The images provided in this Manual are for demonstration purposes only. Details vary slightly based on product version and market region. We have the final right of interpretation on all detailed designs of products.

The information and advice stated are given in good faith and believed to be accurate as of the date of editing. We make no warranties, express or implied, regarding this information.

Table of Contents

1. Product description	01
1.1 Preface	
1.2 Applicable products	
1.3 Brief Introduction	
1.4 Applicable Personnel	
1.5 Usage of Manual	
1.6 Usage of Symbols	
<hr/>	
2. Safety Instructions	03
2.1 Application Scope of Product	
2.2 Safety Usage Instructions	
<hr/>	
3. Delivery	06
3.1 Scope of Supply	
3.2 Identification of Energy Storage Cabinet	
3.3 Integrity Inspection for Transportation	
3.4 Storage of Energy Storage Cabinet	
<hr/>	
4. Installation Design	09
4.1 Mechanical Parameters of Energy Storage Cabinet	
4.2 Ventilation and Heat Dissipation Requirements	
4.3 Cable Design	
4.4 Basic Installation Requirements	
4.5 Installation Environment Requirements	
4.6 Wiring Specifications	
4.7 Fixation and Protection of Connecting Cables	
<hr/>	
5. Mechanical Installation	14
5.1 Transportation of Equipment	
5.2 On-site Installation	
<hr/>	
6. Electrical Installation	21
6.1 Safety Requirements for Electrical Connection	
6.2 Safety Tools and Parts	
6.3 Connection of Electrical Cables	
6.4 Grounding of Energy Storage Cabinet	
6.5 Sealing of Inlet Holes	
6.6 Installation Checklist	
<hr/>	
7. Annex	25
7.1 Technical Data	
7.2 Reference Table for Connecting Cables	
7.3 Quality Warranty	

1. Company Profile

1.1 Preface

Dear user, much appreciation for using the all-in-one air-cooled ESS ECO-E215WS cabinet product developed and produced by Shanghai Elecnova Energy Storage Technology Co., Ltd. We sincerely hope that this product can meet your needs, and we also hope that you will be satisfied with the product performance and provide valuable comments and suggestions. We will continue to evolve and continuously improve product quality.

By fully leveraging the brand effect, technological accumulation, resource advantages, and production and manufacturing experience of both parties in the instrumentation, system integration, low-voltage complete equipment, and related fields, and bring into full play the coordination effect of industrial chain, we focus on the full industrial chain layout of key materials, batteries, battery management, and system integration for lithium energy storage batteries, and are committed to the R&D, manufacturing, sales, and service of lithium energy storage system products, so as to provide customers with efficient, reliable, and customized energy storage solutions.

1.2 Applicable products

This manual is applicable to product model: all-in-one air-cooled ESS cabinet ECO-E215WS.

1.3 Brief introduction

This Manual contains the following main contents:

- Installation Instructions
This Manual introduces the safety precautions for installation of all-in-one air-cooled energy storage cabinet.
- Delivery and Product Description
This Manual introduces the delivery and inspection steps to be implemented by the user after receiving the all-in-one air-cooled energy storage cabinet, and describes the appearance and functions of the product.
- Electrical Installation
This Manual introduces the mechanical installation, electrical installation, communication connection, and installation inspection methods of the all-in-one air-cooled energy storage cabinet, and provides suggestions for design of the product's installation space and electrical wiring.
- other

1.4 Applicable Personnel

This Manual is applicable to those personnel who install and perform other work on this product. Readers need to have certain professional knowledge in electrical, electrical wiring, and mechanical fields, and be familiar with electrical/mechanical schematics and electronic component characteristics.

1.5 Usage of Manual

Please read this Manual carefully before installing this product. Please properly store this Manual together with other materials about energy storage cabinet components, and ensure that the relevant personnel can easily access and use them. In addition to this installation document, the following documents are also available for users to use simultaneously:





- Specification of All-in-one Air-cooled ESS ECO-E215WS Cabinet
- User Manual of All-in-one Air-cooled ESS ECO-E215WS Cabinet
- User Manual of HMI Screen on All-in-one Air-cooled ESS ECO-E215WS Cabinet

The images, logos, and symbols used in this Manual are all owned by Elecnova. No person other than our internal personnel may publicly republish all or any of the contents hereof without written authorization.



1.6 Usage of Symbols

In order to ensure the personal and property safety of user when using this product, or to use this product in an efficient and optimized manner, the relevant information is provided in this Manual and highlighted with appropriate symbols.

The following is a list of symbols that may be used in this Manual. Please read them carefully, so as to better utilize this Manual.

	<p>" DANGER " indicates a hazardous situation which, if not avoided, will result in death or serious injury.</p>
	<p>"WARNING" indicates a hazardous situation which, if not avoided, could result in death or serious injury.</p>
	<p>"CAUTION" indicates a hazardous situation which, if not avoided, may result in minor or moderate injury.</p>
	<p>"Attention" indicates a potential risk, which, if not avoided, may lead to equipment malfunction or property damage.</p>

Please always pay attention to the and warning signs on the cabinet body, which include:

	<p>This sign indicates that there is high voltage inside the cabinet body, and touching it may lead to electric shock.</p>
	<p>This sign indicates that the temperature here is higher than the acceptable range for human body. Please do not touch it arbitrarily, so as to avoid personal injury.</p>
	<p>This sign indicates that the protective grounding (PE) terminal here needs to be firmly grounded, so as to ensure the safety of operators.</p>

2. Safety Instructions

2.1 Application Scope of Product

The all-in-one air-cooled ESS ECO-E215WS cabinet developed and produced by Elecnova is a 400V-output lithium battery pack energy storage product. It provides an interface between power grid and lithium battery, so as to achieve the charging and discharging of lithium battery system. The ECO-E215WS energy storage cabinet products can be directly connected to 400V power grid or load through cables. With the protection level of IP55, this energy storage cabinet product may be installed in both indoor and outdoor environments. The charging/discharging system of the all-in-one air-cooled commercial energy storage cabinet equipped with ECO-E215WS is shown in the figure below:

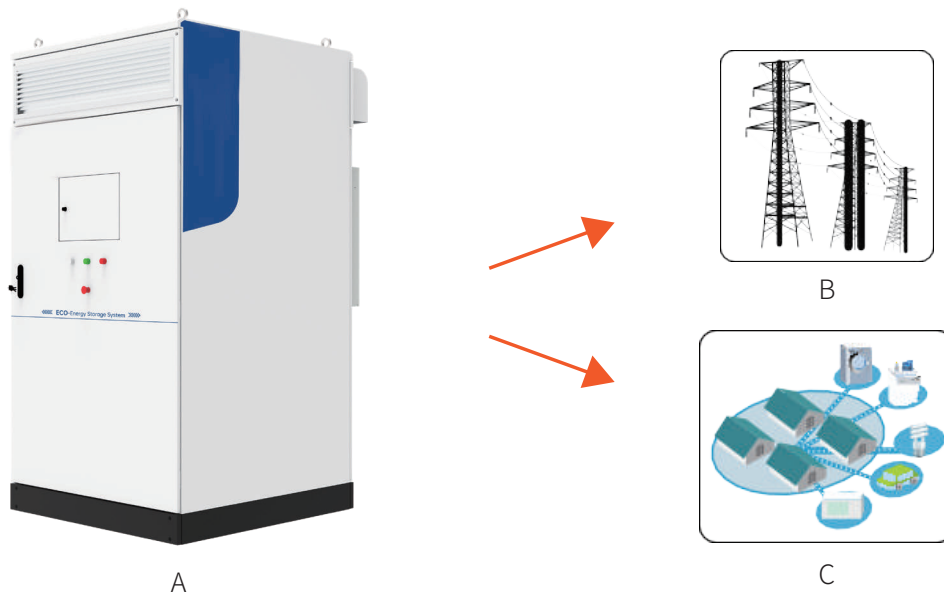

No.	Name
A	All-in-one air-cooled ESS ECO-E215W cabinet (including lithium battery pack)
B	Public power grid
C	Load, and electrical load



All personnel operating ECO-E215WS should be properly trained and qualified. Personnel are expected to read and understand all manuals and project documents and comply with their requirements and instructions.

2.1.1 Safekeeping of Manual

Please read this Manual carefully before using this product, and keep it properly.

Please install the all-in-one industrial/commercial energy storage cabinet in strict accordance with the description in this Manual; otherwise, the serious accidents such as product damage, property damage, and even personal injury/death may occur.

2.2 Safety Usage Instructions

This section introduces the general safety rules that need to be followed when installing the all-in-one air-cooled energy storage cabinet. Please carefully read the safety instructions in this Manual before installation. For specific safety precautions, please refer to the corresponding chapters.



- Touching the contacts and terminals inside the power grid or equipment that are connected to it may lead to electric shock and death!
- Do not touch the terminals or conductors connected to the grid circuit.
- Damaged equipment or system malfunction may cause electric shock or fire!
- Before operation, conduct a preliminary visual inspection on the equipment for any damage or other hazards.
- There is a fatal high voltage inside this product!
- Pay attention to and comply with the warning labels on this product.

2.2.1 Safekeeping of Manual

Please read this Manual carefully before using this product, and keep it properly.

Please install the all-in-one industrial/commercial energy storage cabinet in strict accordance with the description in this Manual; otherwise, the serious accidents such as product damage, property damage, and even personal injury/death may occur.

This Manual contains the important information about transportation and installation of ESS ECO-E215WS cabinet. Before transporting and installing the energy storage cabinet, please read this Manual carefully.

- Please transport, install and operate the energy storage cabinet in strict accordance with the description in this Manual; otherwise, equipment damage, personal injury/death and property damage may occur.
- This Manual shall be properly kept, so as to ensure that the transportation, installation, and operation personnel can access it at any time.
- After the installation is completed, it is prohibited to place any manuals or paper inside the energy storage cabinet.

2.2.2 Personnel Requirements

- Only professional electricians or qualified personnel are allowed to transport, install, and operate this product.
- Operators shall be fully familiar with the composition and working principle of the entire power generation system.
- Operators shall be fully familiar with the Installation Manual and User Manual of this product.
- Operators shall be fully familiar with the relevant standards of the country/region where the project is located.

2.2.3 Protection of Signs on Energy Storage Cabinet Body

- The warning signs on and inside the air-cooled ESS ECO-E215WS cabinet contain the important information for safe operation of the cabinet. It is strictly prohibited to intentionally tear or damage such signs!
- The back panel and the inner side of front door of the air-cooled ESS ECO-E215WS cabinet are equipped with nameplates, which contain the important parameter information related to this product. It is strictly prohibited to intentionally tear or damage such nameplates!



All personnel operating ECO-E215WS should be properly trained and qualified. Personnel are expected to read and understand all manuals and project documents and comply with their requirements and instructions.

2.2.4 Setting of Warning Signs

In the operation room for installation, daily maintenance, inspection and repair of the energy storage cabinet, for the purpose of preventing misoperation or accident caused by approaching of unrelated personnel, please comply with the following instructions:

- Set up clear warning signs at the front and rear switches of the energy storage cabinet, so as to prevent accidents caused by misoperation.
- Set up warning signs or warning tapes near the installation area.
- After the installation is completed, be sure to remove the cabinet door key and keep it properly.

2.2.5 Protection of Lithium Battery

For this energy storage cabinet product, the voltage between positive and negative terminals of lithium battery is very high. If accidentally touched, it may cause electric shock or even personal injury/death.



There is a deadly high voltage between positive and negative terminals of lithium battery pack!

- When maintaining the equipment, ensure that the connection between the all-in-one air-cooled energy storage cabinet and the lithium battery pack has been completely disconnected.

2.2.6 Installation of Equipment

Please install the energy storage cabinet in strict accordance with the description in this Manual.

- In order to avoid the noise generated during energy storage operation and other possible emergencies that may affect the normal life of residents or cause safety accidents, it is preferred to install the energy storage cabinet in outdoor open area.
- The energy storage cabinet shall be kept as far away from residential areas as possible. If necessary, appropriate sound insulation measures shall be taken.
- It is strictly prohibited to stack any combustible or flammable materials around the energy storage cabinet.

2.2.7 Electrical Connection

Electrical connection must be carried out in strict accordance with the description in this Manual and the electrical wiring diagram.



- Select high-quality measurement equipment that meets on-site requirements in terms of measurement range and usable conditions.
- Ensure that the measuring equipment is connected and used in a correct and standardized manner, so as to avoid hazards such as electric arc.
- If conducting live measurements, please take protective measures (such as wearing insulated gloves).

2.2.9 Operation under Completely Powered-off Conditions

Please carry out various operations only when ensuring that the energy storage cabinet is completely powered-off.

- Ensure that the energy storage cabinet will not be accidentally re-powered on.
- Use a multimeter to ensure that the inside of the energy storage cabinet is completely powered-off.
- Implement the necessary ground connection and short-circuit connection.
- Use insulating materials to cover the potentially-live parts near the portion to be operated.
- Throughout the entire operation process, it is necessary to ensure that the external maintenance channels of the energy storage cabinet are unobstructed.

2.2.9 Moisture Protection

For this energy storage cabinet product, the voltage between positive and negative terminals of lithium battery is very high. If accidentally touched, it may cause electric shock or even personal injury/death.



The invasion of moisture is highly likely to damage the all-in-one air-cooled energy storage cabinet!

- Do not open the cabinet door when the air humidity is above 95%.
- Avoid installation operations in rainy or humid weather conditions.

2.2.10 Product Protection

When the energy storage cabinet needs to be discarded, it may not be treated as conventional waste. Please contact a local authorized professional recycling agency.

3. Delivery

3.1 Scope of Supply

The packaging box of the all-in-one air-cooled energy storage cabinet contains the following items (The pictures are for reference only. Please refer to the actual product):



A



B



C

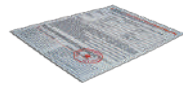

D



E



F

No.	Name	Quantity	Remarks
A	All-in-one air-cooled energy storage cabinet	1 set	Including cabinet door key
B	User manual	1 copy	
C	Installation manual	1 copy	
D	Warranty card	1 copy	
E	Inspection report	1 copy	
F	Certificate of conformity	1 copy	

3.2 Identification of Energy Storage Cabinet

3.2.1 Product Appearance

The front appearance and main components of the air-cooled energy storage cabinet are shown in the figure below.



Figure 3-2 Appearance

No.	Name	Description
A	LED indicator lamp	Used to give power indication, operation indication, and fault indication, respectively
B	LCD touch screen	Used to display data and execute control commands
C	Emergency stop button	To be pressed in emergency, so as to immediately turn off the AC-side power supply of the all-in-one air-cooled energy storage cabinet
D	Door lock	Used to open and close the front door of the all-in-one air-cooled energy storage cabinet

3.2.2 Product Nameplate

The user can identify the all-in-one air-cooled energy storage cabinet through the nameplate, as shown in Figure 3-3. An aluminum nameplate is installed in the lower left corner on the back of the all-in-one air-cooled energy storage cabinet. The information contained in the nameplate includes: model, battery type, main technical parameters, and place of origin of the all-in-one air-cooled energy storage cabinet.



Figure 3-3 Schematic Diagram of Nameplate Position



The nameplate contains the important parameter information related to the all-in-one air-cooled energy storage cabinet, so that it shall be properly protected during transportation, installation, maintenance, and repair. It is strictly prohibited to damage or dismantle it!

3.3 Integrity Inspection for Transportation

The all-in-one air-cooled energy storage cabinet has undergone careful inspection by our personnel and securely packaged before leaving the factory. However, the all-in-one air-cooled energy storage cabinet may still get collided or even damaged during transportation.

3.4 Storage of Energy Storage Cabinet

If the on-site installation is not carried out immediately after the delivery acceptance is completed, the all-in-one air-cooled energy storage cabinet must be stored according to the requirements given in this section. The all-in-one air-cooled energy storage cabinet with outer packaging shall be stored in a ventilated, dry, and clean indoor environment. Meanwhile, the following instructions shall be complied with:

- The packaging shall be returned to its original state, and the desiccant inside the packaging must be retained rather than discarded.
- The storage ground shall be flat and sufficient to bear the weight of the all-in-one air-cooled energy storage cabinet with outer packaging.
- During storage, the equipment shall be well-ventilated and protected against moisture, and the storage environment must be free from accumulated water.
- Temperature of storage environment: -20°C to 55°C ; relative humidity of storage environment: 0-95%, without condensing.
- The surrounding harsh conditions, such as sudden cooling, heating, and collision, shall be properly handled, so as to avoid damage to the all-in-one air-cooled energy storage cabinet.
- Regular inspection shall be conducted, generally not less than once a week. The packaging shall be checked for completeness and damage, so as to avoid insect and rodent bites. If there is any damage to the outer packaging, it shall be replaced immediately.
- If the equipment has been stored for more than six months, the packaging shall be opened for inspection, the desiccant shall be replaced, and then the equipment shall be repackaged.

4. Installation Design

4.1 Mechanical Parameters of Energy Storage Cabinet

The packaging box of the all-in-one air-cooled energy storage cabinet contains the following items (The pictures are for reference only. Please refer to the actual product):

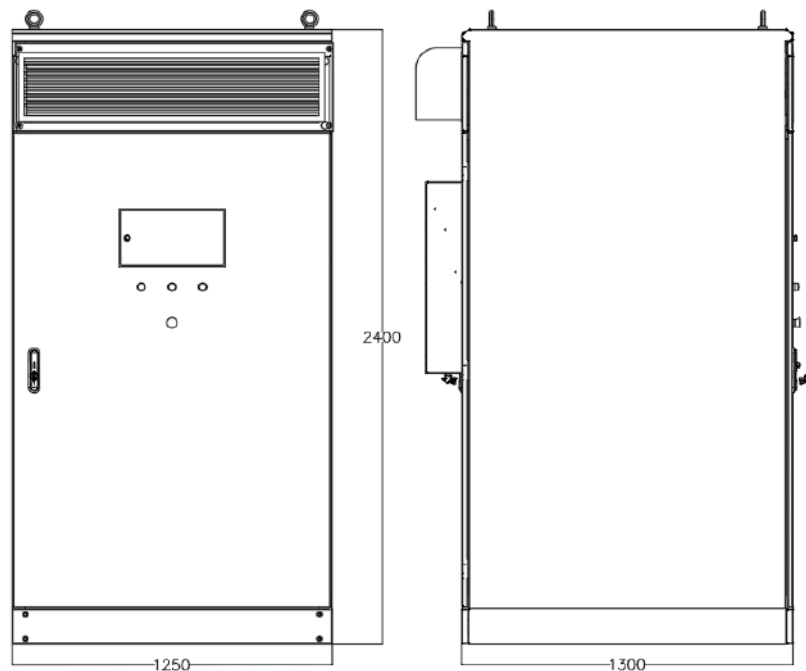

Figure 4-1 Mechanical Dimensions of All-in-one Air-cooled Energy Storage Cabinet

Width	Depth	Height
1,250mm	1,300mm	2,400mm (excluding lifting ring)

The weight of the all-in-one air-cooled energy storage cabinet is about 2,500kg, subject to actual weighing.

4.2 Ventilation and Heat Dissipation Requirements

The overall design of the all-in-one air-cooled energy storage cabinet adopts a structure of front air inlet and rear air outlet. Cold air enters through the front ventilation fan of the air-cooled energy storage cabinet, as shown in Figure 4-2.

The ventilation fan of the all-in-one air-cooled energy storage cabinet is equipped with an air filter, which is easy to disassemble, clean and replace. Please inspect the air filter on a regular basis, so as to ensure that it is clean.

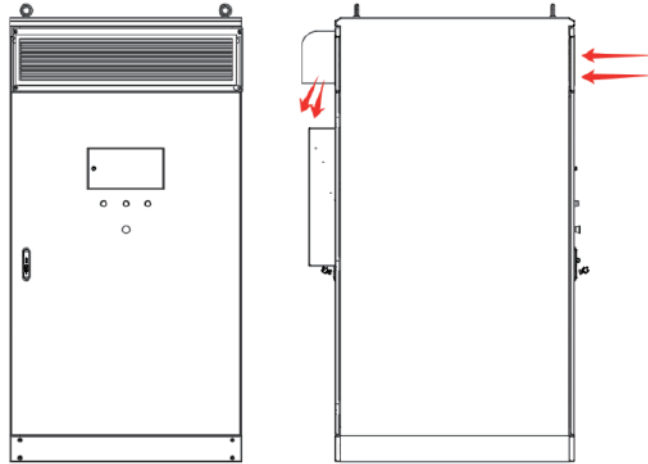

Figure 4-1 Mechanical Dimensions of All-in-one Air-cooled Energy Storage Cabinet

4.3 Cable Design

The all-in-one air-cooled energy storage cabinet in standard configuration has all connecting cables coming in and out from the bottom of the cabinet.

The positions of the inlet and outlet holes are shown in Figure 4-3. The cable in front of the cabinet is communication line, and the cable behind the cabinet is AC-side primary incoming line.

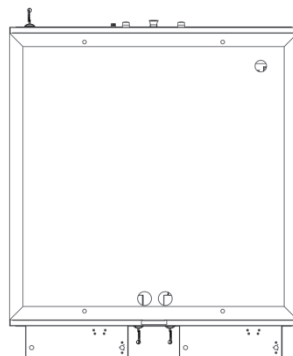

Figure 4-3 Positions of Inlet and Outlet Holes

4.4 Basic Installation Requirements

The protection level of the all-in-one air-cooled energy storage cabinet is IP55. The design of the all-in-one air-cooled energy storage cabinet meets the installation requirements in industrial environments. For the purpose of ensuring the safe and efficient operation of the all-in-one air-cooled energy storage cabinet, please comply with the following instructions when selecting the installation environment:

- Make sure that the installation ground is dry, flat, and free from accumulated water; ensure that the ground is level without shaking and can fully support the weight of the all-in-one air-cooled energy storage cabinet.
- The allowable range of ambient temperature at the installation site is -20°C to 55°C ; the allowable range of relative humidity shall be 0-95% (without condensing).
- Reserve sufficient space in front of and behind the all-in-one air-cooled energy storage cabinet, so as to ensure ventilation, heat dissipation, installation and maintenance, and safe escape.
- The grounding resistance of the all-in-one air-cooled energy storage cabinet shall be less than 4Ω .
- The installation position shall ensure convenient observation of LED lamps and LCD screen.
- There shall be no flammable gases or combustible materials in the installation space.
- The installation environment shall be clean.

4.5 Installation Environment Requirements

The ground, space, cable ducts, air ducts, ventilation equipment, and protective measures in the control room of the all-in-one air-cooled energy storage cabinet shall be strictly designed, so as to meet at least the following requirements.

4.5.1 Foundation Requirements

The all-in-one air-cooled energy storage cabinet shall be installed on a cement foundation or channel steel structure with flame-retardant surface. It is necessary to ensure that the foundation is flat, solid, safe, and reliable, and has sufficient bearing capacity. There shall be neither depression nor inclination on the surface of the foundation.

When constructing the foundation, the cable trenches shall be pre-set based on the overall design of the power station and the cable entry and exit method at the bottom of the all-in-one air-cooled energy storage cabinet. Holes shall be reserved on the foundation, and the size of such holes shall be completely consistent with the positioning holes on the base of the all-in-one air-cooled energy storage cabinet, so that the all-in-one air-cooled energy storage cabinet can be firmly connected with the foundation.

The base of the all-in-one air-cooled energy storage cabinet is equipped with 4 positioning holes, as shown in Figure 4-4 (unit: mm).

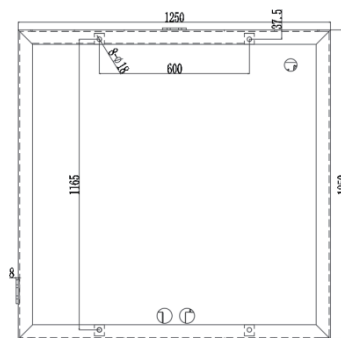

Figure 4-4 Base of All-in-one Air-cooled Energy Storage Cabinet

4.5.2 Space Requirements

When installing the all-in-one air-cooled energy storage cabinet, it is necessary to maintain an appropriate and sufficient distance from the walls and other equipment, so as to meet the requirements related to narrowest maintenance channels, escape routes, and ventilation.

The minimum space requirements for the front and rear of the all-in-one air-cooled energy storage cabinet during normal operation are detailed in the figure below. If the on-site conditions permit, it is recommended to choose a larger spacing, so as to ensure the reliable and efficient operation of the all-in-one air-cooled energy storage cabinet.

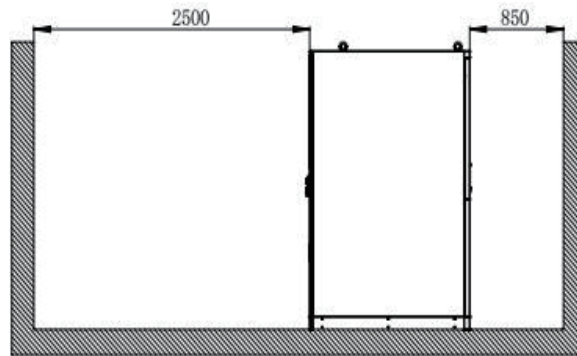

Figure 4-5 Installation Space

4.5.3 Cable Trunking Requirements

The all-in-one air-cooled energy storage cabinet adopts a bottom in and bottom out method. It is recommended that all cables connected to the outside are routed from the cable trench for easy installation and maintenance. Concrete cable trenches shall be pre-set in the electrical control room; or steel brackets shall be installed on the ground inside the control room, so as to raise the installation surface and lay the cables in raised areas (Please see the relevant design standards and codes for details). If cable trenches are preset, they may be fixed and installed with anchor screws or channel steel. If steel brackets are used, the all-in-one air-cooled energy storage cabinet may be directly installed and fixed on such brackets.

The cable trenches are usually designed and constructed by constructor in accordance with the relevant standards, taking into account the weight and dimensions of the equipment.

Good electrical connections are required between cable trays and between cable trays and grounding electrodes.

The cross-section of cable trench is shown in the figure below. Users may determine the number of cable trays according to their needs. When laying cables, the communication cables, control cables, and power cables shall be laid separately, and the DC circuits and AC circuits shall be laid separately. This is beneficial for installation and maintenance, and can reduce the interference of power circuits on communication and control signal lines.

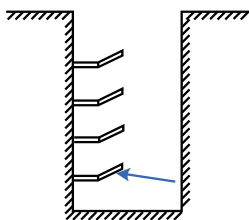

No.	Name
A	Cable trench
B	Cable tray

Figure 4-6 Design of Channel Steel

4.6 Wiring Specifications

The cables used in the system can generally be divided into power cables, power lines, data cables, and communication cables.

When laying communication cables, please stay them away from power cables and maintain right angles at intersections. Try to minimize the length of communication cables and maintain a distance from power cables.

The power cables, power lines, and data cables shall be placed in different cable trenches, so as to avoid the long-distance parallel routing of power cables and other cables, and to reduce the electromagnetic interference caused by output voltage transients.

The distance between power cables, power lines, and data cables shall be greater than 200mm. When the wires are cross distributed, the crossing angle shall be set to 90 degrees, and the distance may be appropriately reduced.

The recommended minimum spatial distance between parallel shielded data cables and power cables and their corresponding relationship with the site are shown in the table below.

Parallel Line Length (m)	Minimum Spatial Distance (m)
200	0.3
300	0.5
500	1.2

The data cables shall be as close to the ground as possible, or be supported by supporting beams, channel steel, or metal guide rail.

4.7 Fixation and Protection of Connecting Cables

4.7.1 Fixation of Cables

In order to prevent loose contact caused by force on copper noses of connecting cables, or heating or even fire caused by increased contact resistance, please ensure that the following torque requirements are met when tightening the screws of such copper noses:

Screw Size	M3	M4	M5	M6	M8	M10	M12	M16
Torque (N.m)	0.7-1	1.8-2.4	4-4.8	7-8	17-20	34-40	60-70	119-140

In order to reduce the stress on copper noses of connecting cables, the cables shall be fixed in appropriate positions.

4.7.2 Protection of Cables



The protection of cables includes the protection of communication cables and power cables. The protective measures are detailed as follows:

- Protection of communication cables: Due to the thin size of communication cables, they are easily pulled apart or detached from the wiring terminals during construction. Therefore, it is recommended to connect the power circuit first, and then connect the communication cables, use cable trays for connection as much as possible, and secure the cables with zip ties in areas without cable trays, and keep the cables away from heating elements and strong electric field circuit cables.
- Protection of power cables: There is a strong current in the power cables, so that during installation and connection, the insulation skin of the cables shall be protected against scratch or damage, so as to avoid short circuits. The power cables must also be properly fixed.

5. Mechanical Installation



5.1 Transportation of Equipment





5.1.1 Precautions

	<ul style="list-style-type: none"> ● Regardless of whether the all-in-one air-cooled energy storage cabinet comes with external packaging or not, it is strictly prohibited to get it tilted during movement. ● The tilt angle shall not exceed 5 degrees. If the tilt angle is too large, the all-in-one air-cooled energy storage cabinet may overturn. Due to its large volume and weight, personal injury/death and equipment damage may occur easily. ● During movement, please avoid mechanical impact on the all-in-one air-cooled energy storage cabinet, such as violent shaking or sudden lowering or lifting. ● The all-in-one air-cooled energy storage cabinet is a whole, and must not be disassembled during transportation or installation. Malfunctions caused by unauthorized modifications are not covered by the warranty. ● Always pay attention to the center of gravity marking on the packaging box of the all-in-one air-cooled energy storage cabinet! Due to the fact that the center of gravity is not the mechanical center of the all-in-one air-cooled energy storage cabinet, please always pay attention to the center of gravity marking of the all-in-one air-cooled energy storage cabinet during transportation. ● Avoid transporting the all-in-one air-cooled energy storage cabinet under rainy or adverse weather conditions. If unavoidable, please take necessary protective measures. ● Only those personnel with corresponding qualifications and authorized by the industry are allowed to transport the all-in-one air-cooled energy storage cabinet.
	<p>In order to ensure the safe and intact transportation of the all-in-one air-cooled energy storage cabinet to the final installation site, please take necessary auxiliary measures.</p>

5.1.2 Transportation with Outer Packaging

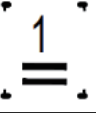
In order to ensure that the all-in-one air-cooled energy storage cabinet is properly protected during transportation, please transport it with packaging as much as possible in accordance with the signs on the packaging. The packaging signs are illustrated as follows:

Sign	Meaning
	<p>Right side up. It is prohibited to place the air-cooled energy storage cabinet horizontally, tilted or upside down.</p>
	<p>Handle with care. Avoid damage to the all-in-one air-cooled energy storage cabinet caused by excessive collision and friction in the transportation environment.</p>
	<p>Moisture prevention. Protect the all-in-one air-cooled energy storage cabinet from and against rain or moisture</p>

Sign	Meaning
	The limit of stacking layers is 1 layer
	No Rolling
	Reusable
	Label of category-9 dangerous goods

The unpackaged all-in-one air-cooled energy storage cabinet may be moved with forklift, pallet truck or crane. When moving the all-in-one air-cooled energy storage cabinet, please pay attention to its weight as well as the center of gravity marking and lifting marking on the packaging box. Ensure that the transportation equipment has sufficient load-bearing capacity and arrange support or lifting points reasonably.

● Transportation with Forklift

Transporting the all-in-one air-cooled energy storage cabinet with a forklift is a standard transportation method. During transportation, the center of gravity of the box shall be placed between the two forks of the forklift and a trial forking shall be conducted. The length of fork shall not be less than 1.6m.

When using a forklift to lift, lower, and move the all-in-one air-cooled energy storage cabinet, please ensure that the operation is slow and smooth. In addition, only place the all-in-one air-cooled energy storage cabinet on a sturdy and stable ground.

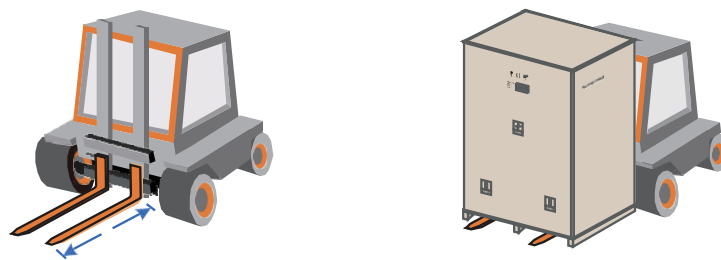

Figure 5-1 Schematic Diagram of Transportation with Forklift

During the entire process of transportation with forklift, please strictly follow the safety operating procedures for forklift. The large size of the all-in-one air-cooled energy storage cabinet may block the driver's line of sight, so that auxiliary personnel shall be arranged to give assistance.

● Transportation with Crane

A crane may be used to lift and transport the all-in-one air-cooled energy storage cabinet. For the purpose of lifting, tie two flexible lifting straps to the outer packaging box through lifting signs. The equipment shall be lifted with the hook being perpendicular to the equipment's center of gravity. Tilting transportation is strictly prohibited!

When using a crane to lift, lower, and move the all-in-one air-cooled energy storage cabinet, please ensure that the operation is slow and smooth. In addition, only place the all-in-one air-cooled energy storage cabinet on a sturdy and stable ground.

During the entire process of transportation with crane, please strictly follow the safety operating procedures for crane. In case of adverse weather conditions such as heavy rain, heavy fog or strong winds, the lifting operation shall be stopped.

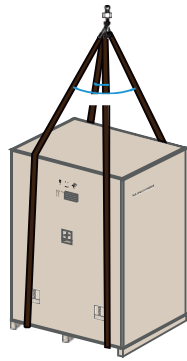

Figure 5-2 Schematic Diagram of Transportation with Crane

5.1.3 Transportation without Outer Packaging

The transportation of all-in-one air-cooled energy storage cabinet without outer packaging is usually carried out near the final installation location. The unpackaged all-in-one air-cooled energy storage cabinet may be transported by using forklift, crane or other means.



Before moving the all-in-one air-cooled energy storage cabinet to the predetermined position, it is recommended to lay the cables on the DC and AC sides first. Due to the thickness of such cables, once the all-in-one air-cooled energy storage cabinet is installed, it will be difficult to carry out cable routing operations and it will be easy to damage the cables.

● Transportation with Forklift

During the entire process of transportation with forklift, please strictly follow the safety operating procedures for forklift.

When using a forklift to lift, lower, and move the all-in-one air-cooled energy storage cabinet, please ensure that the operation is slow and smooth. In addition, only place the all-in-one air-cooled energy storage cabinet on a sturdy and stable ground.

If the unpacking location is closer to the installation location, a forklift may be used to transport the all-in-one air-cooled energy storage cabinet with a bottom wooden pallet. Please ensure that the center of gravity of the all-in-one air-cooled energy storage cabinet is placed between the two forks of the forklift.

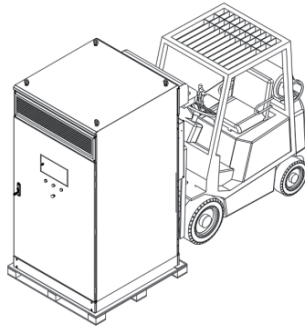

Figure 5-3 Transportation with Forklift (with Bottom Wooden Pallet)

The transportation of all-in-one air-cooled energy storage cabinet without outer packaging is usually carried out near the final installation location. The unpackaged all-in-one air-cooled energy storage cabinet may be transported by using forklift, crane or other means.

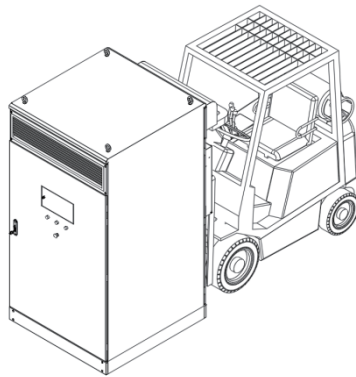

Figure 5-4 Transportation with Forklift (without Bottom Wooden Pallet)

● Transportation with Crane

For the purpose of facilitating the transportation with crane, the lifting rings are designed on the top and door of the all-in-one air-cooled energy storage cabinet. Users may directly lift and transport the all-in-one air-cooled energy storage cabinet through lifting rings.

During lifting operation, the center of the hook shall be perpendicular to the center of the all-in-one air-cooled energy storage cabinet, and a trial lifting shall be carried out. Tilted lifting is strictly prohibited. Meanwhile, during the lifting of the all-in-one air-cooled energy storage cabinet, please strictly follow the safety operating procedures for crane.

When using a crane to lift, lower, and move the all-in-one air-cooled energy storage cabinet, please ensure that the operation is slow and smooth. In addition, only place the all-in-one air-cooled energy storage cabinet on a sturdy and stable ground.



Figure 5-5 Transportation with Crane

5.2 On-site Installation



- It is prohibited to perform any mechanical operation unrelated to installation inside or on the top of the all-in-one air-cooled energy storage cabinet.
- During installation, please ensure the cleanliness of the inside and surrounding environment of the all-in-one air-cooled energy storage cabinet.

5.2.1 Removal of Packaging



The packaging plates of the all-in-one air-cooled energy storage cabinet are all heavy. When removing the outer packaging, please ensure that at least two workers are performing this operation simultaneously.

Please disassemble the transportation packaging box of the energy storage cabinet in accordance with the following steps.

Step 1: Remove the top plate of the packaging box.

Step 2: Remove the wooden side of the packaging box.

Step 3: Remove the shielding material from the packaging box.

Step 4: Remove the anchoring components that secure the all-in-one air-cooled energy storage cabinet to the transportation board.

At this point, the all-in-one air-cooled energy storage cabinet can be separated from the wooden transportation pallet.

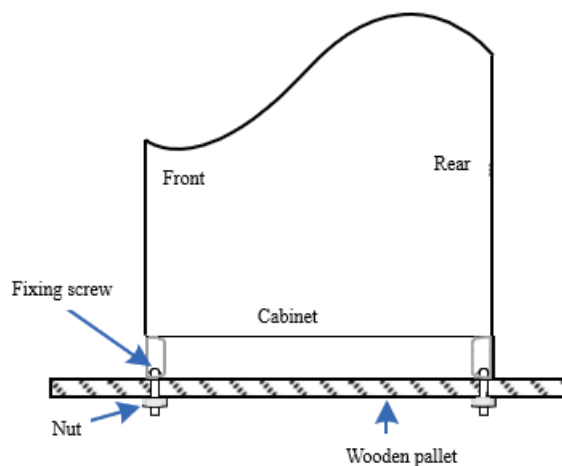



Figure 5-6 Schematic Diagram of Fixing Status of All-in-one Air-cooled Energy Storage Cabinet and Bottom Wooden Pallet

	<p>After the all-in-one air-cooled energy storage cabinet is separated from the wooden pallet, it is strictly prohibited to transport the all-in-one air-cooled energy storage cabinet through the wooden pallet again. In addition, since now the all-in-one air-cooled energy storage cabinet is at risk of tipping over, please protect it properly.</p>
	<p>The all-in-one air-cooled energy storage cabinet may be packaged in accordance with the reversed steps. Please keep the shielding materials and desiccants inside the box during packaging operation, and store the all-in-one air-cooled energy storage cabinet in strict accordance with the description in this Manual.</p>

5.2.2 Inspection before Fixation

It is recommended to finally fix the all-in-one air-cooled energy storage cabinet onto channel steel. Before finally fixing the all-in-one air-cooled energy storage cabinet, please:

- Ensure that the laying of cable trenches meets the installation requirements of the all-in-one air-cooled energy storage cabinet.
- Ensure that the installation and opening of channel steel meet the installation requirements of the all-in-one air-cooled energy storage cabinet.

In addition to using channel steel to fix the all-in-one air-cooled energy storage cabinet, anchor screws may also be used to fix the all-in-one air-cooled energy storage cabinet on a pre-built solid foundation. In such case, it is necessary to pre-drill holes on the foundation, and the size of the holes must meet the requirements of the positioning holes at the bottom of the all-in-one air-cooled energy storage cabinet.

5.2.3 Fixation of Energy Storage Cabinet

	<p>The AC side of the all-in-one air-cooled energy storage cabinet shall be placed close to the later-stage external transformer, so as to minimize the length of the three-phase connecting cable from the AC side of the all-in-one air-cooled energy storage cabinet to the later-stage transformer.</p>
---	---

Complete the fixation of the all-in-one air-cooled energy storage cabinet in accordance with the following steps:

Step 1:

Choose the appropriate tool to transport the all-in-one air-cooled energy storage cabinet to the installation position and align it with the installation holes.

Step 2:

Use M16 bolts to fix the all-in-one air-cooled energy storage cabinet to the channel steel or foundation through the waist holes on the base.

Step 3:

Install the front and rear baffles of the base of the all-in-one air-cooled energy storage cabinet, so as to complete the fixation of the all-in-one air-cooled energy storage cabinet.

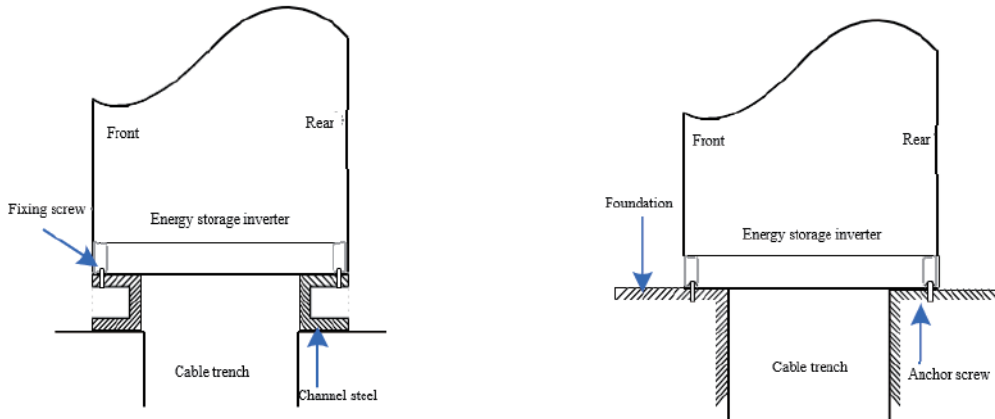
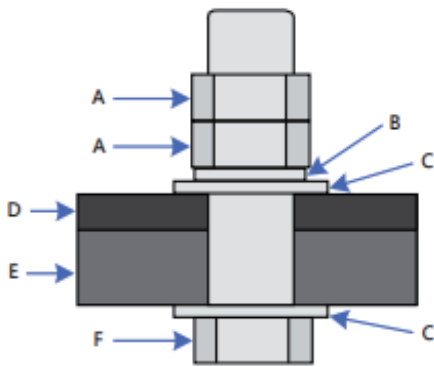

Figure 5-7 Fixation Method for All-in-one Air-cooled Energy Storage Cabinet

The connection sequence between the bottom of the all-in-one air-cooled energy storage cabinet and the channel steel is shown in the figure below.



No.	Name
A	Nut
B	Spring gasket
C	Flat gasket
D	Base of all-in-one air-cooled energy storage cabinet
E	Channel steel
F	Bolt



High voltage! Electric shock!

- Be sure not to touch any live part!
- Please ensure that both the AC and DC sides are not live before installation.
- Due to the high temperature of certain parts of the energy storage inverter, do not place it together with flammable and explosive materials.



- All electrical connections must comply with the electrical connection standards of the country/region where the project is located.
- The all-in-one air-cooled energy storage cabinet may be connected to the power grid only after the permission has been obtained from local power supply company and it has been installed by professional technical personnel.
- Only professional electricians or qualified personnel are allowed to carry out electrical connection for this product.
- Please perform the wiring operation in strict accordance with the wiring markings inside the equipment.

6. Electrical Installation

6.1 Safety Requirements for Electrical Connection

In order to ensure the safety of personnel and equipment during electrical connection, please follow all safety instructions in this Manual, especially those in this chapter, and comply with the relevant safety regulations in the country/region where the installation is carried out.

During the electrical connection to the all-in-one air-cooled energy storage cabinet, as well as all other operations carried out on the all-in-one air-cooled energy storage cabinet, please always follow the following five safety rules:

- Disconnect all external connections of the all-in-one air-cooled energy storage cabinet and the connection to the internal power supply of the equipment.
- Ensure that the energy storage cabinet will not be accidentally re-powered on.
- Use a multimeter to ensure that the inside of the energy storage cabinet is completely powered-off.
- Implement the necessary ground connection and short-circuit connection.
- Use insulating materials to cover the potentially-live parts near the portion to be operated.

6.2 Safety Tools and Parts

The following tools and parts must be prepared before installation:

- Torque wrench
- Screwdriver
- Terminal squeezer
- Alcohol torch
- Internal hexagonal wrench for terminal fixation
- Megohmmeter and multimeter
- Other auxiliary tools and parts that may be used



Before conducting any electrical wiring, please conduct insulation and integrity inspection on all connecting cables. Wires with poor insulation performance, partially-exposed wires, or otherwise damaged wires pose significant safety hazards and must be replaced immediately.

- Before wiring, ensure that the polarity of the DC-side cable is correct and the phase sequence of the AC-side cable is consistent.
- During electrical installation, do not forcefully pull cables or wires, so as to avoid damaging their insulation performance.
- Ensure that all cables and wires have a certain amount of bending space.
- Take necessary auxiliary measures to reduce the stress borne by cables or wires.
- After each wiring operation is completed, please carry out inspection carefully, so as to ensure that the wiring is correct and firm.

6.3 Connection of Electrical Cables

6.3.1 Overview of Wiring Areas

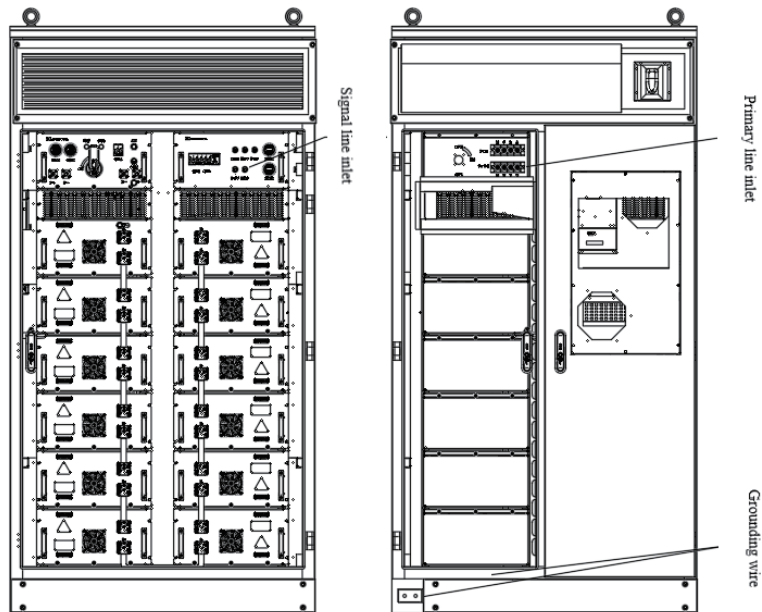



6.3.1 Overview of Wiring Areas

6.3.2 Cable Requirements for Electrical Wiring

The requirements for cable selection are as follows:

- The selected cables must have sufficient current carrying capacity. The current carrying capacity of a conductor is at least related to the factors such as environmental conditions, type of insulation material on such conductor, laying method, material of such conductor, and cross-sectional area of such conductor.
- The wire diameter of all cables must be selected according to the maximum current on the AC and DC sides of the all-in-one air-cooled energy storage cabinet, and there must be margin left.
- The connecting wires on the same side shall have the same specifications and wire type.
- Please select flame-retardant cables.

No.	Name	Description
1	Main power cable	AC A, B, C and N (50-70mm ² cables recommended)
2	Communication connecting cable	485
3	Grounding	PE (25-50mm ² cable) or grounding flat steel

	Overloading of cables is strictly prohibited!
	The cable diameters given in the table are all for copper cables. If aluminum cables are selected, please select the cable size reasonably based on the on-site situations. The parameters such as input number and cable specifications in the table are those of the cables recommended for all-in-one air-cooled energy storage cabinet in standard configuration. If you have special requirements, please inform our staff when placing the order. Please refer to the actual product you purchased for specific values.

6.3.3 Cable Connection

The requirements for cable selection are as follows:

Step 1:

Confirm that the batteries in the front stage of the all-in-one air-cooled energy storage cabinet are all in a disconnected state.

Step 2:

Peel off the insulation skin at the end of the cable. The length of the insulation skin stripped off at the end of the cable shall be about 5mm more than the depth of the copper nose pressing wire hole.

Step 3:

Based on the selected cable specifications, it is recommended to use DT XX-8 copper nose for wiring, where XX is the wire diameter of the selected cable.

Step 4: Crimp the copper nose.

- (1) Place the exposed copper core of the stripped wire head into the crimping hole of the copper nose.
- (2) Use a terminal extruder to compress the copper nose. The number of crimping shall be at least two.



Step 5: Install the heat shrink tubing.

- (1) Select a heat shrink tubing that matches the cable size, of which the length shall exceed the copper nose crimping conduit by about 2cm.
- (2) Wrap the heat shrink tubing over the copper nose until the crimping hole of the copper nose is fully covered.
- (3) Use a hair dryer to tighten the heat shrink tubing.



Step 6: Connect the wires.

- (1) Select the screws that match the copper nose.
- (2) Crimp the copper nose onto the DC wiring copper bar and install it in the order as shown in the figure below.
- (3) Tighten the screws with screwdriver and wrench. The tightening torque of copper cables is 20N.m.

Step 7: Confirm that the wiring is secure.

	<ul style="list-style-type: none"> ● Please comply with all safety regulations listed by the relevant on-site equipment manufacturers. Incorrect wiring sequence may cause fire. Please pay attention to the connection sequence of components. ● When connecting wires, ensure that the connectors are securely fastened. If the connection is insufficient or the contact surface oxidizes, excessive heat may be generated, which may lead to fire.
	<ul style="list-style-type: none"> ● The length of wiring screw shall be appropriate, so that it slightly protrude from the installation hole of copper bar. If it is too long, it may affect the insulation performance or even lead to short circuit. ● Inspect whether there is any heat shrink tubing clamped at the connection between the copper nose and the copper bar. If clamped, it shall be removed immediately; otherwise, it may cause poor contact and even get heated and damaged. ● If the multi-core cables are used, it is recommended to add protective sleeves at each forked location, so as to prevent cracking of outer insulation skin.

6.4 Grounding of Energy Storage Cabinet

	<p>The grounding cables must be well grounded! Otherwise:</p> <ul style="list-style-type: none"> ● In case of malfunction, it may pose a fatal electric shock hazard to operators! ● Lightning strikes may cause equipment damage! ● The equipment may malfunction! <p>Please perform the wiring operation in strict accordance with the wiring markings inside the equipment.</p>
	<p>When grounding, please comply with the following instructions:</p> <ul style="list-style-type: none"> ● The grounding connection must comply with the grounding standards and codes of the country/region where the project is located. ● The connection between the equipment and the grounding electrode must be tightened and reliable. ● After grounding, the grounding resistance must be measured, which may not exceed.

6.5 Sealing of Inlet Holes

After all electrical connections are completed, please comprehensively and carefully inspect the wiring. After confirming there is no problem, please seal the gaps with fireproof mud, so as to prevent small animals from entering. Protective sponge can prevent the baffle and bottom plate from scratching the incoming and outgoing cables. Please do not remove it.

6.6 Installation Checklist

In order to ensure the normal operation of the equipment, after all installation and wiring are completed, please carry out the following inspections:

Mechanical Installation Inspection	
<input type="checkbox"/>	The energy storage equipment is not deformed or damaged.
<input type="checkbox"/>	There is sufficient space around the energy storage equipment .
<input type="checkbox"/>	The temperature, humidity, and ventilation conditions of the environment where the energy storage equipment is located meet the requirements.
<input type="checkbox"/>	Clear warning signs have been set up near the installation location of energy storage equipment
<input type="checkbox"/>	There are no flammable, explosive or hazardous materials near the installation location of energy storage equipment
Electrical installation inspection	
<input type="checkbox"/>	The grounding of energy storage equipment is complete and firm.
<input type="checkbox"/>	The power line connection of the all-in-one air-cooled energy storage cabinet is correct and firm.
<input type="checkbox"/>	The communication line is connected correctly and kept at a certain distance from other cables.
<input type="checkbox"/>	The number and identification of cables are correct and clear.
<input type="checkbox"/>	The insulated protective cover is complete and reliable, and the warning signs are clear and firm.

Other Inspections	
<input type="checkbox"/>	There are no missing tools, parts, conductive dust generated by drilling operation or other foreign objects inside the cabinet.
<input type="checkbox"/>	The equipment is neat, and the cables are firmly and reliably bound.

7. Annex

7.1 Technical Data

Item	Description	Remark
Product model	ECO-E215WS	
DC		
Cell type	LFP 280Ah	
System grouping	1P240S	
Rated energy	215.04kWh	100%DOD, 25°C, 0.5P
Rated capacity	280Ah	
Rated voltage	768V	
Recommended voltage range	DC 672-864V	Individual cell voltage 2.8v~3.6v
AC		
Rated output power	100kW	
Max. power	110 kW (continuous 1 min)	
Nominal voltage	400 Vac /3P+N+ PE	
Nominal frequency	50Hz / 60Hz	
THDi	< 3%	
DC component	<0.5% I _{pn}	
Power factor	-0.98 lagging ~0.98 leading	

Item	Description	Remark
General		
System efficiency	≥89%	Auxiliary power excluded
Charge/discharge rate	0.5P	constant power
DoD	95%DOD	
Cycle life	≥8000 times (25±2°C)	25±2°C, 0.5P, 95% DOD rated operating conditions
Ingress rating	IP55	
Cooling	forced air cooling	
Operating temperature	-25 ~ 55°C	
Humidity	0 ~ 95% RH, no-condensing	
Altitude	≤2000m	Derating above 2000m
Dimension(W*D*H)	1250*1300*2400mm	
Weight	2500kg	
Fire safety	Smoke/temperature detection + immersive gas(aerosol)	
Connectivity	Ethernet/RS485	
Compliance	GB/T 36276, GB/T 34120, GB/T 34131, UN38.3, IEC62619, UL1973, UL9540, and CE-EMC	

7.2 Reference Table for Connecting Cables

In order to ensure the normal operation of the equipment, after all installation and wiring are completed, please carry out the following inspections:

No.	Name	Description
1	Main power cable	AC A, B, C and N (50-70mm ² cables recommended)
2	Communication connecting cable	485
3	Grounding	PE (25-50mm ² cable) or grounding flat steel

7.3 Quality Warranty

The warranty period of this product is subject to the contract. During the warranty period, if a product malfunctions We are will provide free repair or replace the product with a new one.

● During the warranty period, we will require customers to provide invoices of the purchased product and prove the purchase date. In addition, the trademark on the product shall be clearly visible, otherwise we have the right not to provide the quality warranty services.

● Conditions

- The unqualified products shall be handled by us after replacement.
- The customer shall reserve reasonable time for us to repair the faulty equipment.

● Exemption from Liability

Under any of the following circumstances, we have the right not to provide the quality warranty services:

- The equipment and its components have exceeded the free warranty period
- The equipment has been damaged during transportation
- The equipment has been installed, modified or used incorrectly
- The equipment has been operated in extremely harsh environments beyond those described in this Manual
- The equipment malfunctions or gets damaged due to installation, repair, modification, or disassembling by personnel other than our service personnel
- The equipment malfunctions or gets damaged due to use of any component or software that is not standard or is not provided by us
- The equipment is installed or used beyond the scope as specified in relevant international standards
- The damage is caused by abnormal natural environment

For malfunctions caused by the above circumstances, if the customer requests us to provide repair services, the paid repair services may be provided after our service department determines such circumstances.

For the purpose of continuously improving customer satisfaction, our products and product manuals are constantly being improved and upgraded. If there is any discrepancy between the manual in your hand and the product, it may be due to version difference. Please refer to the specific product. If you still have any question, please contact us.

● Software Licensing

- It is prohibited to use all or any of the data in the firmware or software developed by us for commercial purposes in any way.
- It is prohibited to decompile, decrypt, or perform any other operation that may damage the original program design on the software developed by us.